

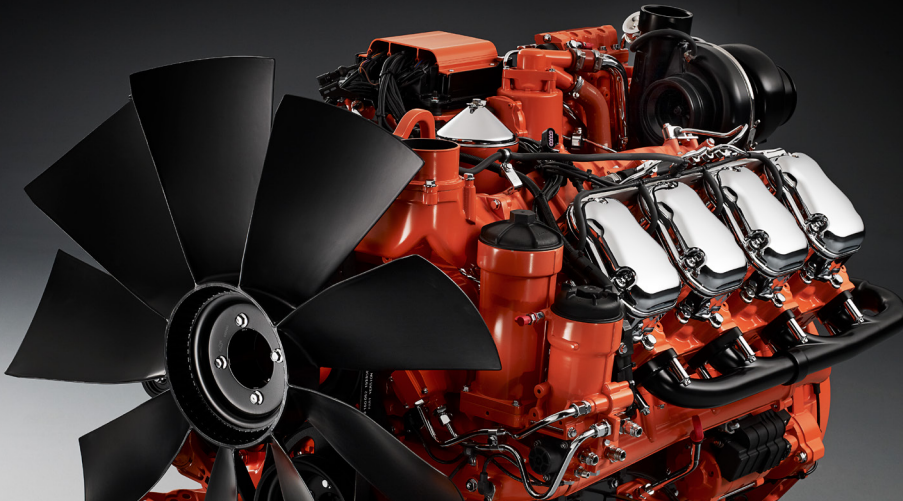

# DC16 093A. 558-634 kW (640-720 kVA)

Fuel optimized



The power generation engines from Scania are based on a robust design with a strength-optimized cylinder block containing wet cylinder liners, which can easily be exchanged. Individual cylinder heads with 4 valves per cylinder promotes reparability and fuel economy.

The engine is equipped with a Scania-developed Engine Management System, EMS, to ensure the control of all aspects related to engine performance.

The injection system is based on electronically controlled unit injectors, which provides good fuel economy and a high torque. The engine can be fitted with many accessories such as air cleaners, PTOs and cooling package, to suit a variety of installations.

### Standard equipment

- Scania Engine Management System, EMS
- Unit injectors, PDE
- Turbocharger
- Fuel filter and extra pre-filter with water separator
- Oil filter, full flow
- Centrifugal oil cleaner
- Oil cooler, integrated in cylinder block
- Oil filler, in valve cover
- Deep front oil sump
- Oil dipstick, in cylinder block
- Magnetic drain plug for oil draining
- Starter motor, 1-pole 7.0 kW
- Alternator, 1-pole 100 A
- Flywheel, SAE 14
- Silumin flywheel housing, SAE 1 flange
- Front-mounted engine suspension
- Open crankcase ventilation

	Engine speed (rpm)			
	1500 rpm (50 Hz)		1800 rpm (60 Hz)	
	PRP	ESP	PRP	ESP
Gross power (kW)	558	614	576	634
Gross power (kVA)	640	706	652	720
Fuel consumption at full load (g/kWh)	197	198	202	207
Fuel consumption at 3/4 load (g/kWh)	189	189	199	199
Fuel consumption at 1/2 load (g/kWh)	193	192	204	202
Heat rejection to coolant (kW)	189	219	209	242

**PRP – Prime power:** For continuous operation at varying load. Max. mean load factor of 70% of rated power over 24 h of operation. 1 hour/12 hour period above 100% load. Max. 25 h accumulated service time above 100% load per year.

**ESP – Stand-by power:** For operation under normal varying load during a power outage. Not overloadable. Max mean load factor of 70% of rated power over 24 h of operation. Not for applications intended for more than 200 h/year.



# DC16 093A. 558-634 kW (640-720 kVA)

Fuel optimized

## Engine description

No of cylinders	90° V8
Working principle	4-stroke
Firing order	1 - 5 - 4 - 2 - 6 - 3 - 7 - 8
Displacement	16.4 litres
Bore x stroke	130 x 154 mm
Compression ratio	15.7:1
Weight	1340 kg (excl oil and coolant)
Piston speed at 1500 rpm	7.7 m/s
Piston speed at 1800 rpm	9.24 m/s
Camshaft	High position alloy steel
Pistons	Steel pistons
Connection rods	I-section press forgings of alloy steel
Crankshaft	Alloy steel with hardened and polished bearing surfaces
Oil capacity	40-48 dm <sup>3</sup>
Electrical system	1-pole 24 V DC

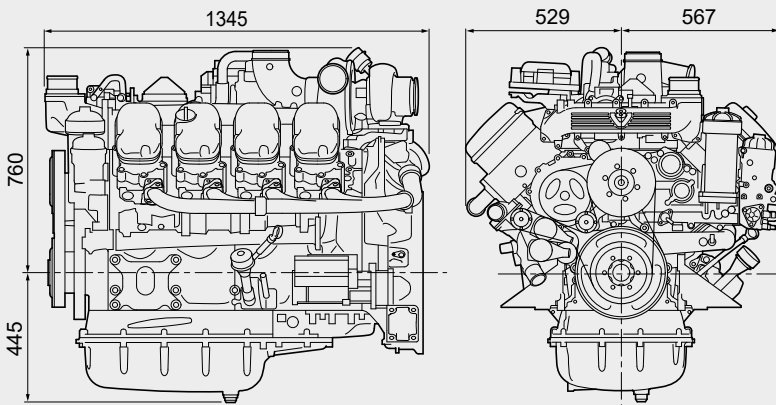

All dimensions in mm



# SCANIA