



SG ENERGY



Installation and Operation Maintenance Manual -Diesel Generator Sets



Versions: V2021

Table of Contents

Product Identification Information.....	0
Foreword.....	1
Safety Precautions.....	2
1.Introduction.....	7
1.1 Naming Conventions.....	7
1.2 Genset power rating.....	8
1.3 Genset configuration.....	9
1.4 Name plate.....	10
2. Genset Installation.....	11
2.1 Adequate ventilation.....	11
2.2 Outdoor Installation.....	12
2.3 Positioning of Walk-in Containers.....	13
2.3.1 Concrete Plinth.....	14
2.3.2 Moving the Generatorset.....	14
2.4 Foundations and Vibration Isolation.....	16
2.4.1 Foundation.....	16
2.4.2 Vibration Isolation.....	16
2.5 Storage.....	17
2.5.1 Genset storage.....	17
2.5.2 Engine Storage.....	18
2.5.3 Alternator Storage.....	18
2.5.4 Battery Storage.....	18
2.6 The machine room layout instructions.....	18
2.7 Unit-Mounted Radiator Cooling.....	19
2.7.1 System Features.....	19
2.7.2 Installation Considerations.....	20
2.8 Remote Radiator Cooling.....	21
2.8.1 General.....	22
2.8.2 Vent Lines.....	23
3. Exhaust System Installation.....	24
3.1 Flexible Exhaust Line.....	24
3.2 Condensation Trap.....	25
3.3 Piping.....	25
3.4 Exhaust Outlet.....	26
3.5 Exhaust System Backpressure.....	26
4. Fuel System Installation.....	27
4.1 Main Tank.....	27
4.2 Tank location.....	28
4.3 Day Tanks.....	29
4.4 Fuel Lines.....	30
4.5 Auxiliary Fuel Pumps.....	30
5. Genset Operations.....	31
5.1 General Instructions.....	31
5.2 Start the genset.....	31
5.2.1 Preparation before starting.....	31
5.3 Stop the genset.....	33
5.3.1 Stop the Genset.....	33
5.3.2 Emergent stop.....	34
5.4 Start genset under cold environment.....	34

6. Control Module Operation Guide.....	35
6.1 DSE3110 control system.....	35
6.2 DSE4520 Control system.....	39
6.3 DSE7320 Control system.....	42
6.4 Other control system.....	48
7. Gensets Maintenance.....	49
7.1 Diesel engine maintenance.....	49
7.1.1 Cooling system.....	49
7.1.2 Lubricating system.....	51
7.1.3 Fuel system.....	52
7.1.4 Intake and exhaust system.....	53
7.2 Alternator maintenance.....	55
7.2.1 Inspection before start.....	55
7.3 Battery instruction and maintenance.....	56
7.3.1 Connect and disconnect.....	56
7.3.2 Cleanup.....	56
7.3.3 The battery charging.....	56
7.4 Heater.....	57
8.Maintenance Plan.....	58
8.1 Routine maintenance.....	58
8.2 Every 200-400 working hours.....	58
8.3 Every 800 working hours.....	59
8.4 Every 1200 working hours.....	59
8.5 Per 2500hours or as needed.....	59
9. Troubleshooting Guide.....	60
9.1 Diesel engine.....	60
9.2 Alternator.....	64
9.3 Electric control.....	64
10. Warranty Guide.....	67
11. Remarks.....	68

Product Identification Information

Product identification numbers determine service parts. Record the product identification numbers in the spaces below immediately after unpacking the products so that the numbers are readily available for future reference. Record field-installed kit numbers after installing the kits.

Generator Set Identification Numbers

Record the product identification numbers from the generator set nameplate(s).

Model Designation _____

Specification Number _____

Serial Number _____

Accessory Number	Accessory Description
_____	_____
_____	_____
_____	_____
_____	_____
_____	_____
_____	_____
_____	_____
_____	_____
_____	_____
_____	_____
_____	_____
_____	_____
_____	_____
_____	_____
_____	_____
_____	_____
_____	_____
_____	_____
_____	_____
_____	_____

Controller Identification

Record the controller description from the generator set operation manual, spec sheet, or sales invoice.

Controller Description _____

Engine Identification

Record the product identification information from the engine nameplate.

Manufacturer _____

Model Designation _____

Serial Number _____

Alternator Identification

Record the product identification information from the engine nameplate.

Manufacturer _____

Model Designation _____

Serial Number _____

Foreword

Thank you for choosing Company's products!

This manual of Company's generator sets Operation and Maintenance contains information for the correct operation and maintenance of your generator set and important safety and installation information, including troubleshooting guidelines.

. (Hereinafter diesel generator set is referred as genset).

This manual must be kept with the genset at all times.

Most accidents happened in operation, maintenance and repairs, which caused by ignoring the basic security rules, preventive actions and correct operation. Most accidents can be avoided If operators recognize all kinds of potential danger before it happens. Operators must notice the potential danger and be trained to be competent to use tools correctly, avoiding possible risks. The operation, maintenance and repairs must only be carried out by authorized and competent personnel

Before operating, maintaining or fixing the genset, carefully read and fully understand the following safety regulations and check all local requirements. This will reduce the possibility of personnel injury, damage to the equipment or improper service.

If any components need to be changed, we recommend to use our own components or those with same technical regulations. It may cause personal injury and damage to the equipment if non-compliant components being used.

The information contained in this manual was based on the genset in production at the time of publication. Company's reserves the right to update any portion of this information without notice.

The serial number is shown on the nameplate of each genset, which should be kept properly. Please advise Company's of this serial number if you are in need of spare parts or assistance from Company's.

Please contact us if you meet any problem in this manual that is incompletely covered or not mentioned. We will appreciate it and propose solutions to you in the soonest possible time.

Safety Precautions

Please read this chapter carefully. It has great importance to your personal safety and the life of the genset. It provides basic safety precautions which should be taken during the maintenance.

Daily check items

Carefully check the genset and the machine room before starting or after turning off the genset. This will help you to discover the diesel fuel, coolant or lubricant leakage and some unusual circumstances that have occurred or will occur.

Refuel

When refueling, there is risk of fire and explosion. No smoking & must shut down the genset. Do not overfill the tank. Firmly tighten the fuel tank filler cap after refueling.

Only use the fuel and lubricant which are recommended in this manual. Using of inappropriate fuel and Lubricant may lead to operation problems, even cause the damage to engine and reduce the genset operation life.

Carbon monoxide poisoning

Only start the genset in a well-ventilated place. If install the genset in a closed space, please ensure there is good ventilation, so that exhaust gas generated by the engine can be discharged from the working area properly.

Operation and maintenance

If you are not sure how to operate the genset, please do not operate it. You should contact with Company's distributor in your country or contact with Company directly. All the maintenance and reparation must be conducted after genset turned off.

Before every starting, please do the routine check. Checking the genset regularly according to the maintenance period which is recommended in this manual.

Most of the chemicals, such as antifreeze, anti-rust agents are harmful to health. So please be especially careful at the time of using these chemicals.

It is very dangerous to approach the running genset. Loose-fitting clothing, hair, fingers or falling tools may be

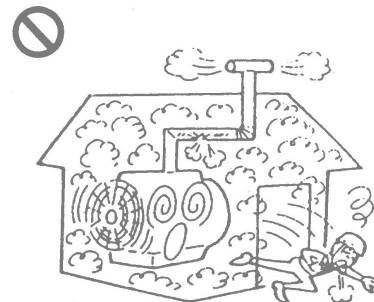
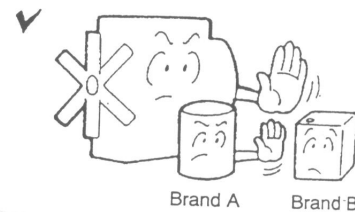
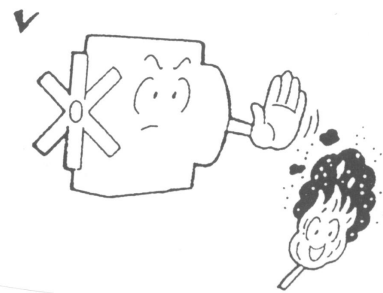
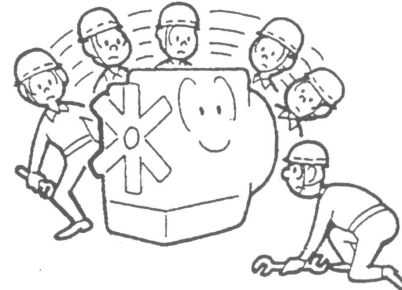

Safety Precautions

entangled into the rotating parts of the engine and cause serious injury. There is risk of electric shock while approaching the alternator.

You must wear protective gloves when you look for the leakage section or points. High pressure fuel from the fuel system will penetrate the skin and cause serious injury, even septicemia. Hot lubricant can also cause burns. So, do not start the genset when the lubricating filler cap is open.

There is a risk of being burnt when working on a high-temperature engine, pay attention to the hot surface.

Do not remove the coolant filler cap before the engine cooled down. Otherwise, steam or hot coolant may be ejected and cause burn.

Before checking and repairing electrical system, please ensure to turn off the genset and cut off the main breaker power. the battery contains corrosive electrolyte. While charging battery or moving batteries, it is necessary to protect the skin and clothes, and be sure to wear protective glasses and gloves. If the battery electrolyte is spilled on the skin, wash immediately with plenty of water and soap; if the electrolyte is splashed into eyes, rinse immediately with plenty of water, and go to the hospital right afterwards.

Operation and maintenance records

There is operation and maintenance record form supplied with the genset. As a running log, each starting, shut down, the operating parameters of each one hour should be recorded, each time maintenance and troubleshooting should be recorded in the appropriate form. The record table is the most important information for warranty and failure analysis. In case that you fail to provide true and valid original records, you will lose the right to claim for warranty.

For unattended genset, the data of each routine inspection and maintenance should be recorded as well.

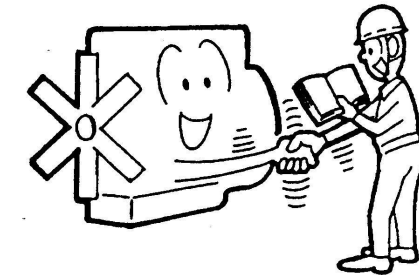
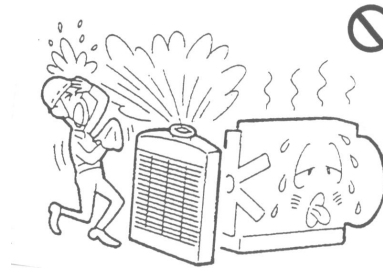

Before operating and maintaining genset, please read the regulations and requirements stated in the instructions carefully. The operating in violation of instructions may cause injury to personnel and damage to equipment.

Safety Information

- The safety symbols: There are corresponding safety symbols on the proper location of the genset. Please identify and understand these safety symbols correctly.
- Genset transportation and lifting safety
 - ! According to the weight stated on the genset nameplate to select the appropriate slings or use proper lifting vehicles. Overloading lifting or overloading transportation is prohibited.
 - ! Two or more than two people when operating the genset is a must. Make sure non-alone operation.
 - ! When lifting height exceeds the height of the operator, the operator should wear a helmet.
 - ! Moving the genset while the genset is running is prohibited. Make sure to move the genset after it have been shut down for quite a long time. Drain fuel when transporting the generator over long distances or rough terrain.
 - ! Before transportation, please ensure that all components of the genset are firmly installed, access door is locked in place, and the parts which are loose easily during transportation have already been fixed.
 - ! Please be sure to take corresponding rain proof actions when transporting genset.
- Genset operation and maintenance safety
 - ! Please train operator before operating and maintaining the genset. Ensure that the operation and maintenance are conducted according to operation and maintenance manual. Ensure to use the correct spare parts for the maintenance.
 - ! Install the genset correctly according to operation and maintenance manual. Installation, maintenance and repairs must be conducted by authorized personnel who have the technical capability.
 - ! Genset parameters are factory-configured. Please do not arbitrarily modify them. The modification must be done by technical engineers.
 - ! Please use gloves for protection when you refilling in antifreeze, replacing the antifreeze, fuel, lubricant.

Safety Information

filter or battery.

- ! Please wear a helmet and protective footwear when operating on the genset or inside the canopy.
- ! Please never wear loose clothes, tie, and jewelry during operation. Please use ear defenders when you operate the genset inside a closed space.
- ! Please make sure to turn off the genset, disconnect battery before maintaining, checking, changing lubricant, adding coolant, replacing filters, adjusting the belts or tightening the mounting bolts.
- ! When the protection guard of the alternator and engine fan has been removed, never try to start the genset, or try to put your hand and head into it.
- ! For preventing splashing scalding, opening the radiator cap when the genset is still running or before the coolant cool down is prohibited.
- ! Regularly checking if there are any items around may interfere the operation. For ensure a safe operation environment, please clear them out in a timely manner.
- the emergency stop button needs regular check to ensure the proper function of it.
- ! Ensure reliable earth connection.
- ! Non-professional operators are not allowed to disassemble any parts of engine, alternator or control system.
- ! Never ingest fuel, lubricating oil, antifreeze, electrolyte, and never touch these fluids. Once you are exposed to these fluids, you should use the water to wash immediately.
- ! The genset should use the output cable witch meet the voltage class standard, the cable end must be protected.
- ! Make sure to check the bolt connection after a period time of running. And make sure to tighten them regularly.
- ! After disassembly, please make sure to put the electrical external shield back to the original location.

■ Extinguishing(Fire Safety)

- ! Prohibit smoking or using naked flames when checking the battery, operating and maintaining the genset.
- ! Inflammable and explosive materials cannot be stored inside the machine room, silent canopy or near the genset. Check the fuel/lubricant tube and surrounding of the genset regularly to see if there is any leakage. When maintaining the genset, ensure that no fuel/lubricant splashed to the insulation of the

canopy. If any splash found, clean it up immediately.

- ! The machine room should be equipped with fire extinguishers. Please check them regularly and make sure that they are always in good condition.
- ! Used cotton contaminated with oil which should be cleared up in time, and shall not be stacked inside or around the genset.

■ Machine room environment

- ! Ensure keep good ventilation in the machine room.
- ! Genset emissions are harmful, and should not be ranked in the machine room. The exhaust gases need to be discharged to the outside through the exhaust pipe.

1.Introduction

1.1 Naming Conventions

1.1.1 General Diesel gensets

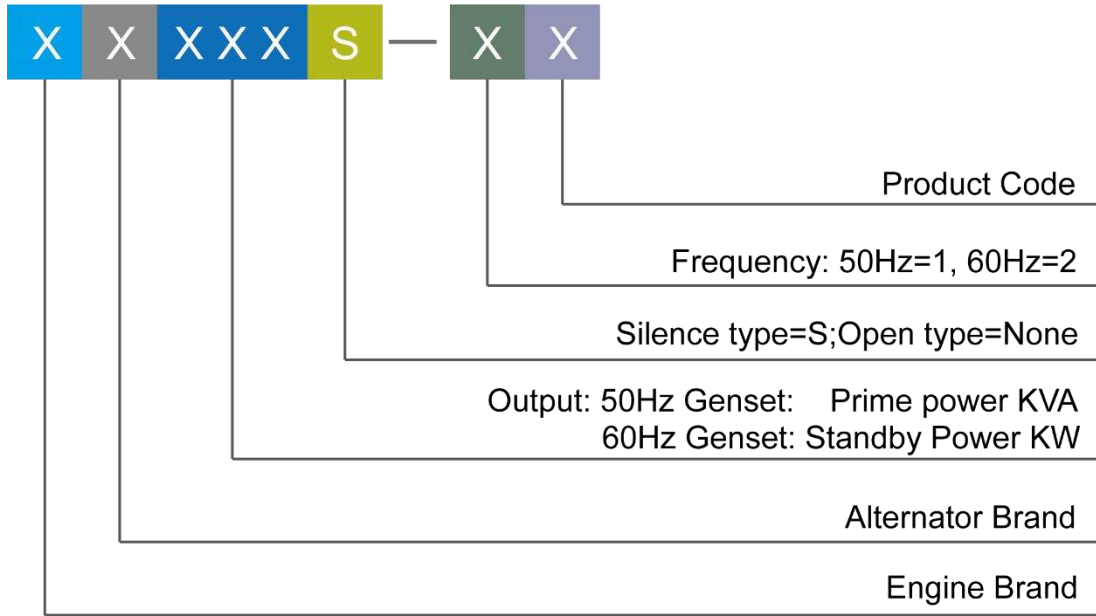

1.1.2 Trailer diesel genset

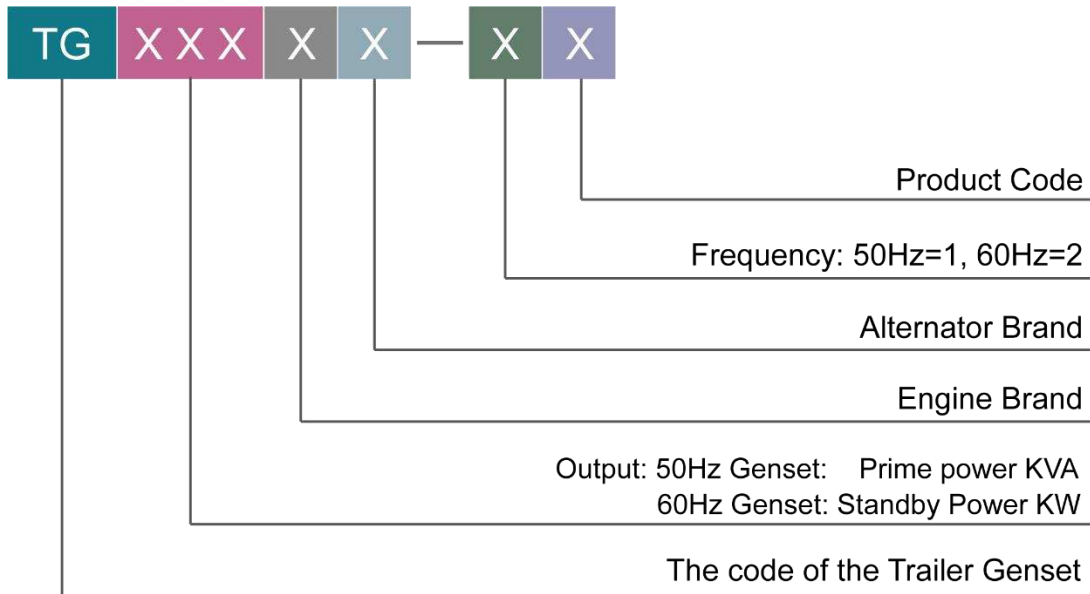

1.2 Genset power rating

1.2.1 Genset standard power conditions

Genset can output the power rating stated on the name plate under following standard environmental conditions:

- a) Altitude \leq 1000m;
- b) Ambient temperature: \leq 40 °C;
- c) Relative humidity: \leq 90%;

If the operating environment of the genset does not conform to the environmental conditions above, then the output power need to be corrected.

The proposed power correction should be carried out according to the following criteria:

Altitude: Each additional 300m beyond the standard environmental conditions (altitude 1000m), power decreased by 2%;

Temperature: Each 5 °C higher than environmental conditions (temperature 40 °C), power decrease 4.0%.

1.2.2 Company genset power rating is in accordance with ISO standard. There are three ways can be used to presented the power rating.

- a) Prime power: Replace the main power grid, provide power to the variable load mode. Overload of 10% is permitted for 1 hour in every 12 hours operation.
- b) Standby Power: Power available at variable load in the event of a main power network failure. No overload is permitted.
- c) Continuous power: Within the predetermined maintenance cycle, under the specified environmental conditions, the power is delivered for unrestricted running hours.

The power rating on the Company genset name plate according below rules:

- 50HZ genset: prime power(kVA) .
- 60HZ genset: standby power(kW).

1.2.3 Power correction

When the genset works under condition which not conform to the 1.2.1 article, then its power output should be corrected.

$$P = K1 * K2 * K3 * Pe$$

- P –The actual output under real working conditions (kW)
- K1-diesel engine correction factor (K1 = 1.0, when continuous working hours is no more than 12h. K1=0.9 when running hours more than 12h)
- K2-ambient temperature correction factor ; K3-altitude correction factor
- Pe – Genset rating power (kW)

Different brands of engine have their own correction starting point (altitude and temperature), please refer to the engine and alternator manual or contact with Company.

The correction is according to the following standard:

Elevation: every 300m higher than the standard condition (1000m), power drop 2%

Temperature: every 5°C increase from standard environment condition, power drop 4.0%.

Introduction

1.3 Genset configuration

1.3.1 Genset structure

There are two types of Company gensets, open type and silent type.

The open type genset which below (include) 625kVA come with base fuel tank. For safety, open type genset above 625kVA comes without base fuel tank.

The silent type genset is open type genset with silent canopy. So, the genset operation noise is significantly reduced. Silent genset comes with base fuel tank. For genset above 625kva, the silent canopy is standard container. Optional fuel tank is located inside the container.

Please refer to below drawing for detail.

Figure1-1: the open type genset. **Figure1-2:** the silent type genset

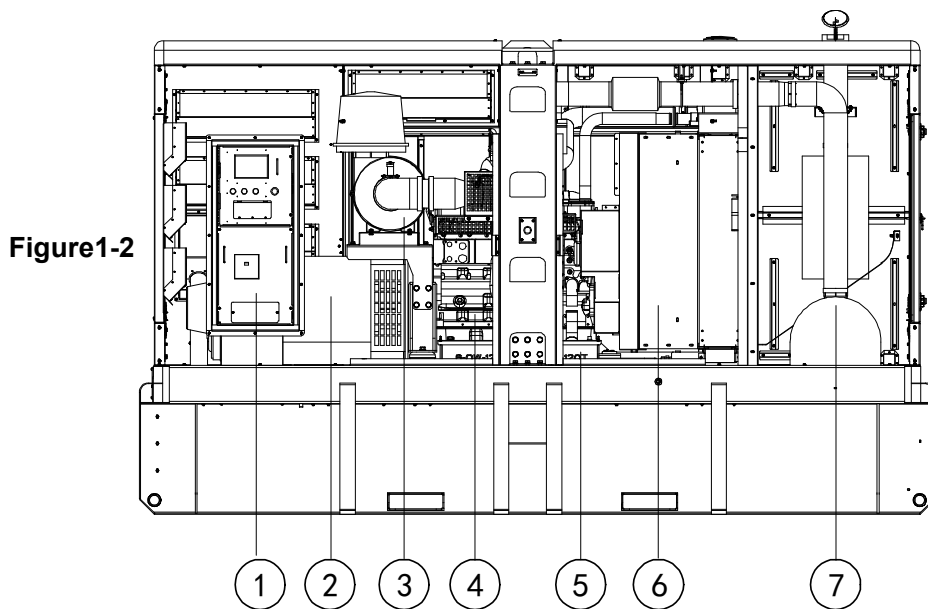
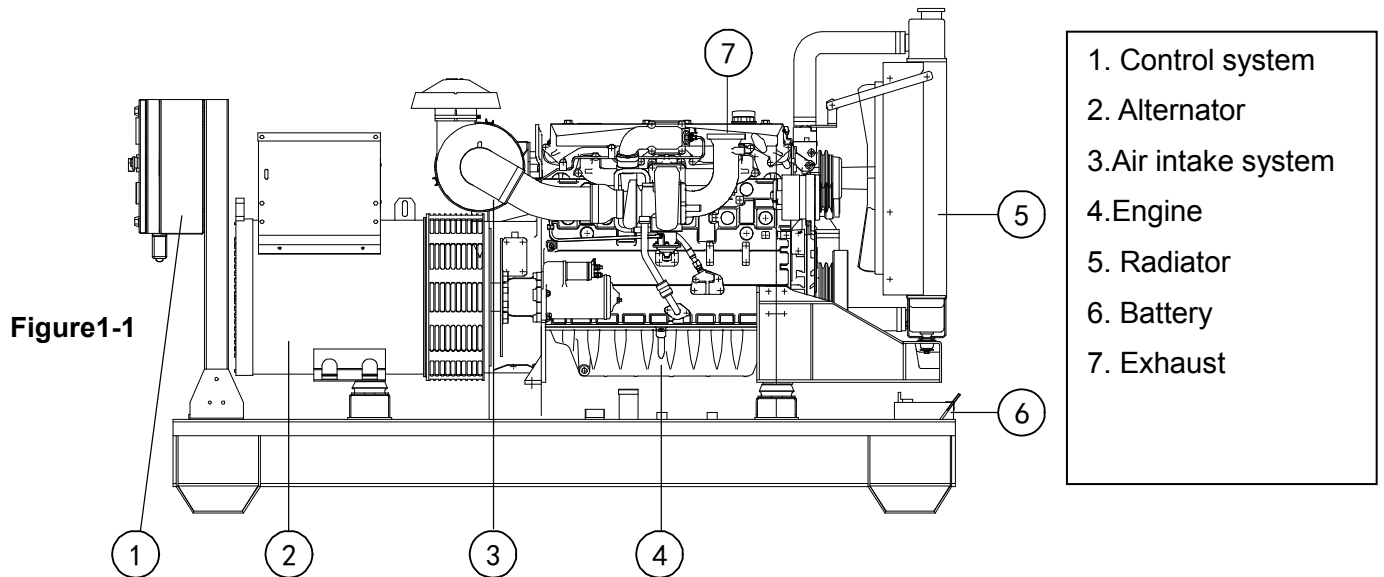

- 1.3.2 Engine: According the different power range, Company gensets adopt with world famous brand engines, such as Cummins, Perkins, FPT-Iveco, Doosan, Deutz, and Volvo which are powerful with reliable performance, low emission, low fuel consumption and easy maintenance characteristic.
- 1.3.3 Alternator: Company gensets adopt world famous self-excitation alternator as well as Company' own brands Company alternator. They have high steady-state and transient performance, less waveform distortion, strong overload capability, small radio aggravation, stable operation, low failure rate.
- 1.3.4 Control system: Company genset adopt high-performance control system, it can achieve more accurate operational data monitoring, safer and more comprehensive protection system, more reasonable and more user-friendly operating interface. It also can realize remote control, man-machine interface control, and can be combined with the user's system and realize centralized control.
- 1.3.5 Genset base frame and silent canopy: Company focus on providing high level products to customers, and strive to design the base frame and canopy more reasonable size and achieve the highest performance. The well designed canopy in line with international trends, reflecting the industry characteristics. The structure is simple and the disassembly is easy. Silent canopy can be dissembled as individual shipping items, so as to reduce shipping cost.
- 1.3.6 Optional devices as following:
- Heating devices which suitable to work in low temperature regions
 - External fuel return expansion port
 - Convenient AC output plugs
 - ATS
 - Multi-gensets paralleling system
 - Remote communication
 - Large capacity external fuel tank and pump

1.4 Name plate

The name plate is located on the side of the genset base frame. It contains following information:

Genset model, serial number, produce date, prime power, frequency, RPM, voltage, phase, power factor, dimensions, weight etc. As the Graph 3 shown

2. Genset Installation

1.5 Documents and accessories

Please refer to the “accessories list” in the carton for detail information about documents and accessories. Please check the document and accessories according the list. If any is missing, please contact Company.

2. Genset Installation

Correct installation of genset is the foundation of proper operation. In order to meet the operation and maintenance requirement, we suggest customer to built a machine room for genset, especially for open type genset,

In addition to meet the requirements for genset normal operation, the room design should also meet the requirements of the local laws regarding the extinguishing and protection.



Prior to installation, please read carefully the requirements and safety instructions regarding installation and operation, and ensure safety, correct installation.

2.1 Adequate ventilation

This section discusses factors important in the effective and safe installation of the generator set. Selecting a location for the generator set can be the most important part of any installation procedure. The following factors are important in determining the location:

Adequate ventilation.

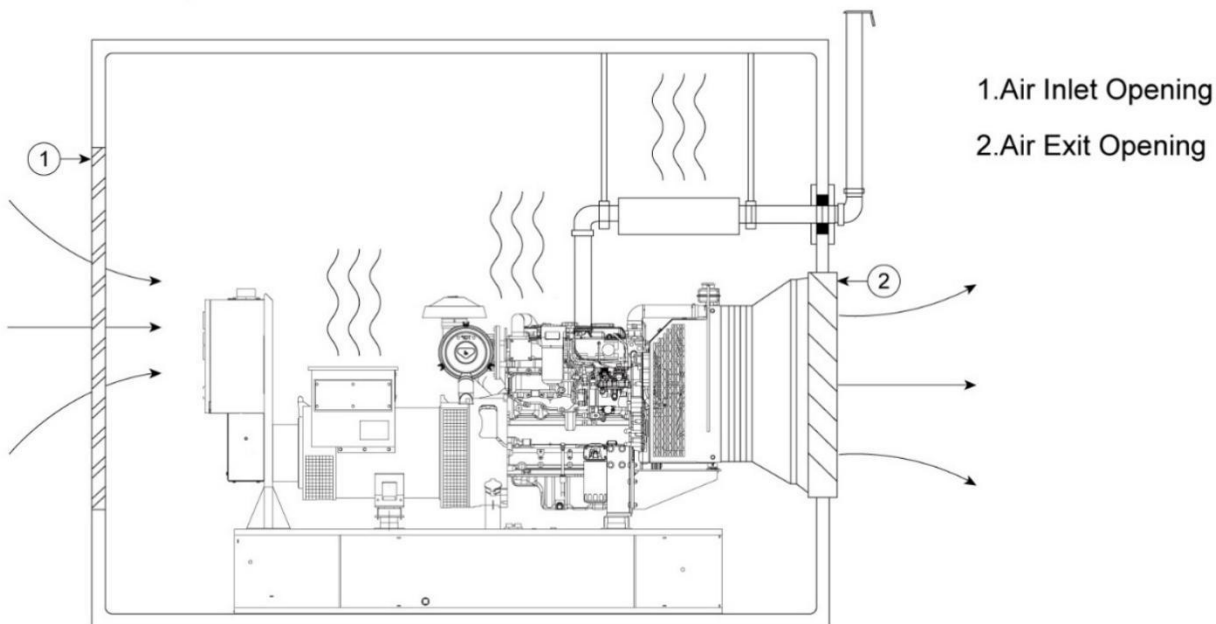

Figure2-1 Typical installation showing generator set ventilation

- Protection from the elements such as rain, snow, sleet, wind driven precipitation, flood water, direct sunlight, freezing temperatures or excessive heat.
- Protection from exposure to airborne contaminants such as abrasive or conductive dust, lint, smoke, oil mist, vapors, engine exhaust fumes or other contaminants.
- Protection from impact from falling objects such as trees or poles, or from motor vehicles or lift trucks.
- Clearance around the generator set for cooling and access for service: at least 1-meter (3ft 3in) around the set and at least 2 meters (6ft 6in) headroom above the set.
- Access to move the entire generator set into the room. Air inlet and outlet vents can often be made removable to provide an access point.
- Limited access to unauthorized personnel.

If it is necessary to locate the generator set outside of the building, the generator set should be enclosed in a weatherproof canopy or container-type housing which is available for all sets.

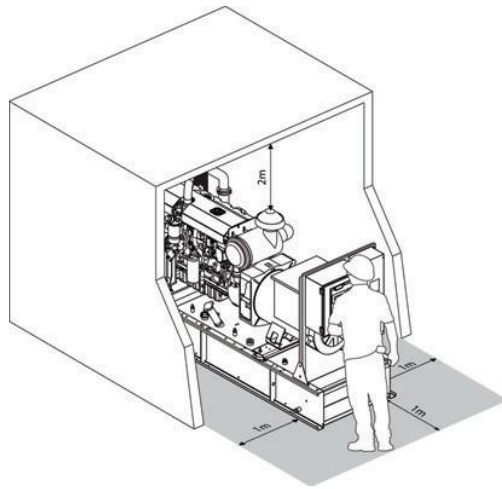

Figure2-2 – Typical installation showing generator set access and operator workstation

2.2 Outdoor Installation

Installation and handling is greatly simplified when the generator set has been equipped with an enclosure. Two basic types may be fitted. The first type is a close fitting canopy enclosure. This will be both weatherproof and sound attenuated. The other enclosure type is a walk-in type container, similar to a shipping container. It may be weatherproof or sound attenuated.

These enclosures provide a self-contained generator set system that is easily transportable and requires minimal installation. They also automatically give protection from the elements and protection from unauthorized access.

Warning:

! Make sure all personnel are out of the canopy or container, if equipped, before closing and latching enclosure doors.

! Before closing canopy or enclosure doors, ensure all obstructions (especially hands and fingers) are clear to prevent damage or injury.

! For transport purposes, some silencer outlets on generator sets housed in walk-in type enclosures will be fitted with cover plates. These are to be replaced with the supplied stub pipes complete with fitted rain hood.

! Ensure there is no debris on the base frame prior to starting, as loose items will cause radiator damage.

Because enclosed generator sets are easily transportable and may be installed and operated in a temporary location,

Genset Installation

many of the fixed installation details given in this chapter may not apply. The following considerations must be taken into account when temporarily installing the generator set:

- Locating the generator set where it will be protected from damage and away from the exhaust fumes of other engines or other airborne contaminants such as dust, lint, smoke, oil mist or vapors.
- Ensure the generator set is not positioned in such a way that it will obstruct the entrance or exit to the area where the it is situated.
- Locating the generator set on firm, level ground which will not subside or be otherwise affected by the vibration caused by the operation of the generator set
- Ensuring that fumes from the exhaust outlet will not be a hazard especially when wind is taken into account.
- Ensure there is enough area around the generator set for access and serviceability.
- Electrical grounding of the generator set at all times, in accordance with local regulations.
- Providing access to refill the fuel tank when required.
- Protecting electrical cables installed between the generator set and the load. If these are laid on the ground, ensure they are boxed in or covered to prevent damage or injury to personnel.

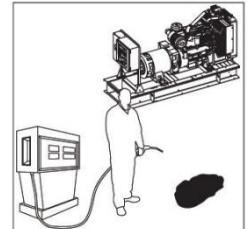
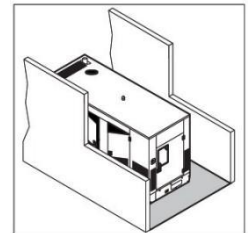
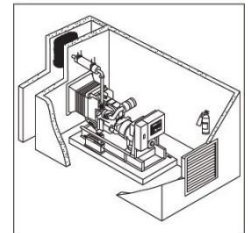
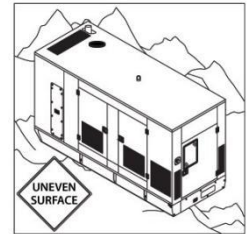
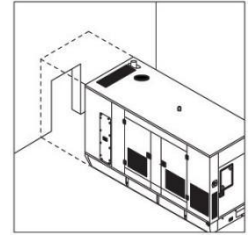

WARNING

! Enclosed generator sets should be installed outside. In the event that the enclosed generator set is installed inside, adequate fresh cooling air must be provided and that both engine and hot coolant air exhausts must be ducted outside the building. The ducting and exhaust pipework must be designed to minimize back pressure which would have a detrimental effect on generator set performance.

2.3 Positioning of Walk-in Containers

Proper installation of the container is required if successful generation of power is to be achieved. The following information must be considered in the selection of the operating site for the container. The containerized generator set must be placed on a flat surface in order to maintain proper alignment. Containers can be successfully installed on a concrete plinth or level, natural surface. The foundation must bear the static weight of the module plus any dynamic forces from engine operation.

Warning:

For generator sets housed in walk-in type containers, crankcase breather outlets terminated at the external face of the enclosure will be plugged. These must be removed prior to operation.

2.3.1 Concrete Plinth

Setting the container on a concrete plinth is the preferred method for permanent installation for both ISO and Design to Order (DTO) containers. The concrete plinth should have been designed to withstand the weight of the container. Please consult the installer for further details.

2.3.2 Moving the Generator set

The generator set base frame is specifically designed for ease of moving the set. Improper handling can seriously damage components.

Using a forklift, the generator set can be lifted or carefully pushed/pulled by the base frame. If pushing, do not push the base frame directly with fork.

Warning:

! Always use wood between forks and the base frame to spread the load and also between the forklift carriage and the side of the canopy to prevent damage.

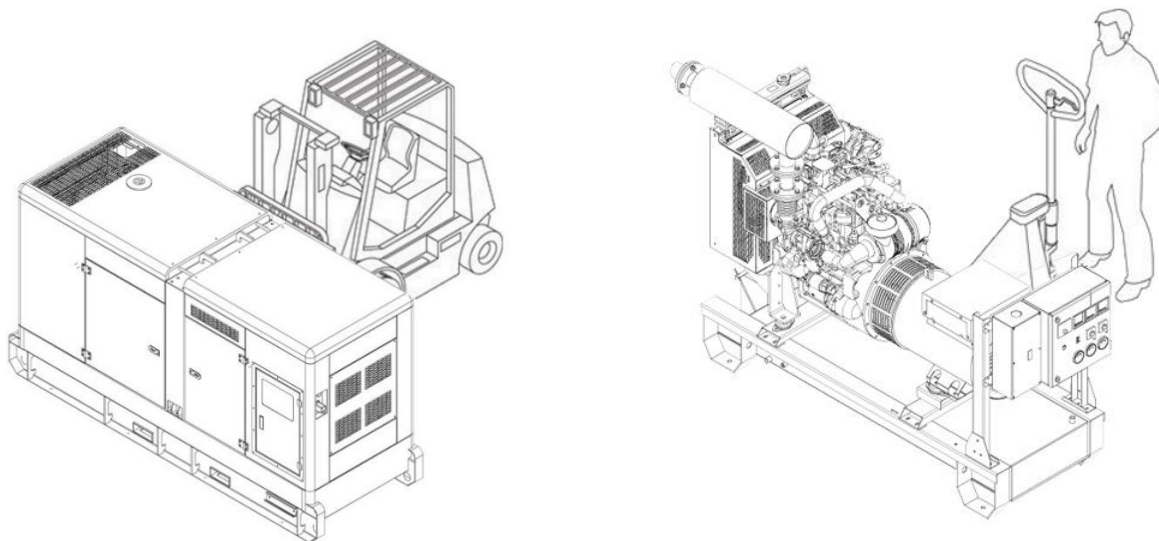

Figure 2-3 – Transporting a generator set using a forklift truck and forklift trolley

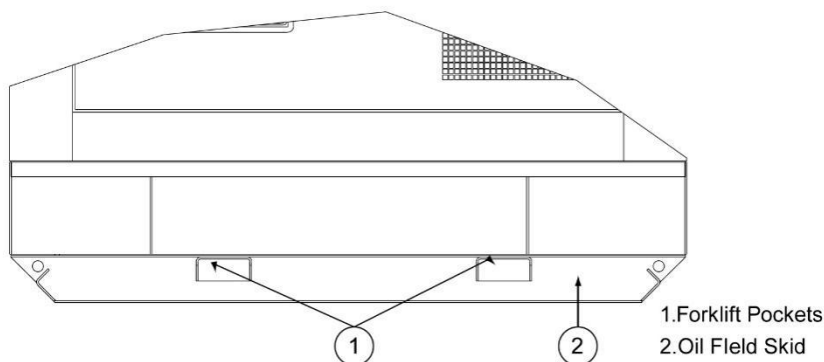

Figure 2-4 – Typical generator set with Oil Field Skid base option

Genset Installation

If the generator set will be regularly moved, it should be fitted with the optional Oil Field Skid which provides forklift pockets in the base frame along with eyes for pulling. The smaller sets have forklift pockets in the base frame as standard.

Warning:

- ! **Please ensure the fuel tank is empty when lifting the generator set to ensure safe and stable lifting.**
- ! **Never lift the generator set by attaching to the engine or alternator lifting lugs.**
- ! **Ensure the lifting rigging and supporting structure is in good condition and is suitably rated.**
- ! **Keep all personnel away from the generator set when it is suspended.**

2.3.3 Genset transportation



Incorrect lifting and transportation may cause damage to the genset.

In order to avoid accidental damage during transportation, please make sure the loading capacity of the transportation equipment should be 1.2 times of the total weight of the genset and its accessories. Packaging the genset safely with necessary rainproof, anti-pressure, anti-bumps actions, so as to ensure that genset will not be damaged during transportation. During transportation, the genset should be fixed firmly inside coach to avoid the parts loose caused by vibration. Prohibit putting any heavy objects on top of the genset. During transportation, people are not allowed to stay inside the genset.

While loading or unloading the genset from vehicle, you should use the appropriate load forklift or lifting equipment to avoid the genset dumping or falling on the ground. When loading or unloading the genset from the container, you should use suspension locomotive carefully elevate diesel genset or carefully push or pull the base of the genset with a forklift. When you push the genset, please do not push genset with forklift rod, you should put a piece of wood or other damping in between. This will disperse the pushing strength and avoid damage to genset. When using the lifting equipment to lift the genset, please use the lifting hole on the base and lifting beams on the open type genset. Please use the lifting eye on top of silent type genset. In order to avoid the unit falling on the ground and even loss of balance swaying, the slings should meet the safety requirements, and the carrying capacity of the forklift fork arm should be greater than the genset weight about 120% to 130%.



It is very dangerous to use the rings on the engine and alternator to lift the genset. It will cause injury and machine damage.

To lift and install the generator set you can use the single / two-point lifting points or the lifting points provided on the base frame. Points of attachment should be checked for cracked welds or loose nuts and bolts before lifting. A spreader bar is required to prevent damage to the generator set whilst lifting from the base frame (see Figure 4h). It should be positioned over the center of gravity, to allow a vertical lift. Guide ropes should be used to prevent twisting or swinging of the generator set once it has been lifted clear of the ground. Place the generator set down on a level surface capable of supporting its weight.

Warning

- ! **Please ensure the fuel tank is empty when lifting the generator set to ensure safe and stable lifting.**
- ! **Centre of gravity decal is located on the base / canopy of the generator set.**

! The center of gravity may not always be located at the center of the generator set.

! Do not attempt to lift in high winds.

2.4 Foundations and Vibration Isolation

The generator set is supplied on a rigid base frame that precisely aligns the alternator and engine and needs only be bolted down to a suitably prepared surface.

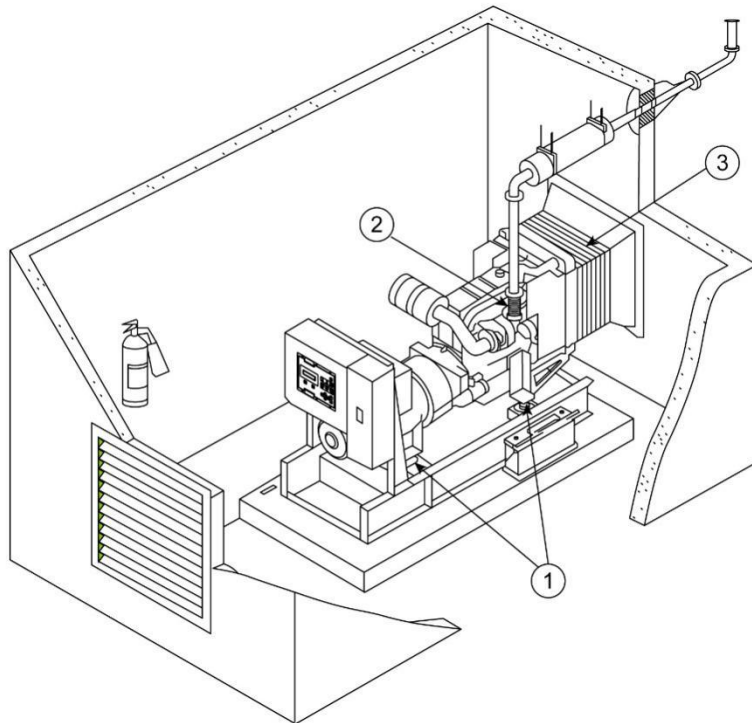

1. Vibration Isolators showing
2. Flexible Exhaust Coupling
3. Flexible Air Discharge Duct

Figure 2-5 – Typical installation vibration reduction techniques

2.4.1 Foundation

A reinforced concrete pad makes the best foundation for the generator set. It provides a rigid support to prevent deflection and vibration. Typically, the foundation should be from 150 mm to 200 mm (6 to 8 inches) deep and at least 150 mm (6 inches) wider and longer than the generator set. The ground or floor below the foundation should be properly prepared and should be structurally suited to carry the combined weight of the foundation pad and the generator set. (If the generator set is to be installed above the ground floor the building structure must be able to support the weight of the generator set, fuel storage and accessories.) Relevant building codes should be consulted and complied with. If the floor is wet from time to time, such as in a boiler room, the pad should be raised above the floor. This will provide a dry footing for the generator set and for those who connect, service or operate it. It will also minimize corrosive action on the base frame.

2.4.2 Vibration Isolation

To minimize engine vibrations being transmitted to the building, the generator set is fitted with vibration isolators. On small and medium sized generator sets these isolators are fitted between the engine/alternator feet and the

base frame. This allows the frame to be rigidly bolted to the foundation. On larger generator sets the coupled engine/alternator is rigidly attached to the base frame and the vibration isolators are supplied loose for fitting between the base frame and the foundation. In all cases the sets should be securely bolted to the ground (either

Genset Installation

through the base frame or through the vibration isolators) to prevent movement.

Vibration isolation is also required between the generator set and its external connections. This is achieved by the use of flexible connections in the fuel lines, exhaust system, radiator air discharge duct, electrical conduit for control and power cables and other externally connected support systems.

Long term storage can have detrimental effects on both the engine and alternator. These effects can be minimized by properly preparing and storing the generator set.

2.5 Storage

2.5.1 Genset storage

In order take full advantage of the warranty period and meet client's usage requirement, we suggest that client shall install and commission the genset soonest possible after receiving. Meanwhile, client should arrange professional technician to responsible for the genset operation and maintenance.

In case the genset have to be stored for a period of time, then the proper storage plan must be considered accordingly. Long-term storage will cause negative impact on the engine and alternator, and the proper storage method will minimize the negative impact to the most. So the proper storage is essential.

The storage of genset should follow some steps, including fully clean the genset, keeping genset in dry, well ventilation place, add appropriate high quality lubricant, fully drain the water from the radiator and anti-rust treatment.

Ensure the safety of the storage place to avoid the damage and injury. Storage place should conform to safety standard and equipped with fire extinguishers.

While long time storage the genset, the coolant may cause the engine cooling system corrosion. In some low temperature area, coolant may frozen and cause damage to the engine. So, please drain the coolant completely before the genset storage. In general, it is required to drain the water from radiator, engine body, water pump (if drain outlet available), Lubricant cooling system (if drain outlet available), water heater jacket (if drain outlet available) and filter. The drain outlets for each machine may be different, please refer to the document come with the genset.

To prevent the moisture entering the main coil of alternator, to prevent the condensation reducing the insulation performance of the alternator and impacting the proper performance of the genset, please make sure genset is stored in dry condition. It is recommended to adopting some special method such as heating and dehumidification apparatus device to make sure the main coil dry. For details, please refer to the document of the alternators.



Warning: The storage environment should avoid overheating, undercooling, sun and rain. It is also very important to maintain the proper humidity.

Genset Installation

The battery in the genset is maintenance-free; it should be recharged every 5-8 weeks to avoid the life time reducing. The battery storage should avoid direct exposure to the sun or rain.

After a period of storage, before the genset put into operation or installation, please check the if there is any damage, any oxidize of the eclectic system, any loose of the connection parts, Check if the main coil of the alternator is still dry, if the genset body is clean. Please take necessary action if needed.

2.5.2 Engine Storage

The engine should be put through an engine “preservation” procedure that includes cleaning the engine and replacing all the fluids with new or preserving fluids. Please consult your local Dealer for more information on engine storage.

2.5.3 Alternator Storage

When an alternator is in storage, moisture tends to condense in the windings. To minimize condensation, store the generator set in a dry storage area. If possible, use space heaters to keep the windings dry.

Please consult your local Dealer for more information on alternator storage.

2.5.4 Battery Storage

While the battery is stored, it should receive a refreshing charge every 12 weeks (8 weeks in a tropical climate) up to a fully charged condition.

2.6 The machine room layout instructions

It is suggested that all the genset should be installed inside the machine room, so as to make sure that genset life time and normal operation will not be negative impacted by sun, rain and sand etc.

Figure2-6 show the standard installation of genset. The principle of the machine room layout as following:

1. Ensure the genset kept away from the sun, rain, sand, overheating, undercooling impaction.
2. Ensure the genset running under the proper condition of intake and exhaust and well ventilation.
3. Ensure to minimize the impaction to the environment caused by noise and exhaust produced by genset.
4. Ensure there is enough space around the genset, so the maintenance can be conducted easily. In general the space which 1.5M away from genset (around and top) should not install or stack anything else.
5. Machine room should meet the fire safety requirement. There should be fire extinguisher available. The genset should keep a safety distance away from the Ignition source.

Genset Installation

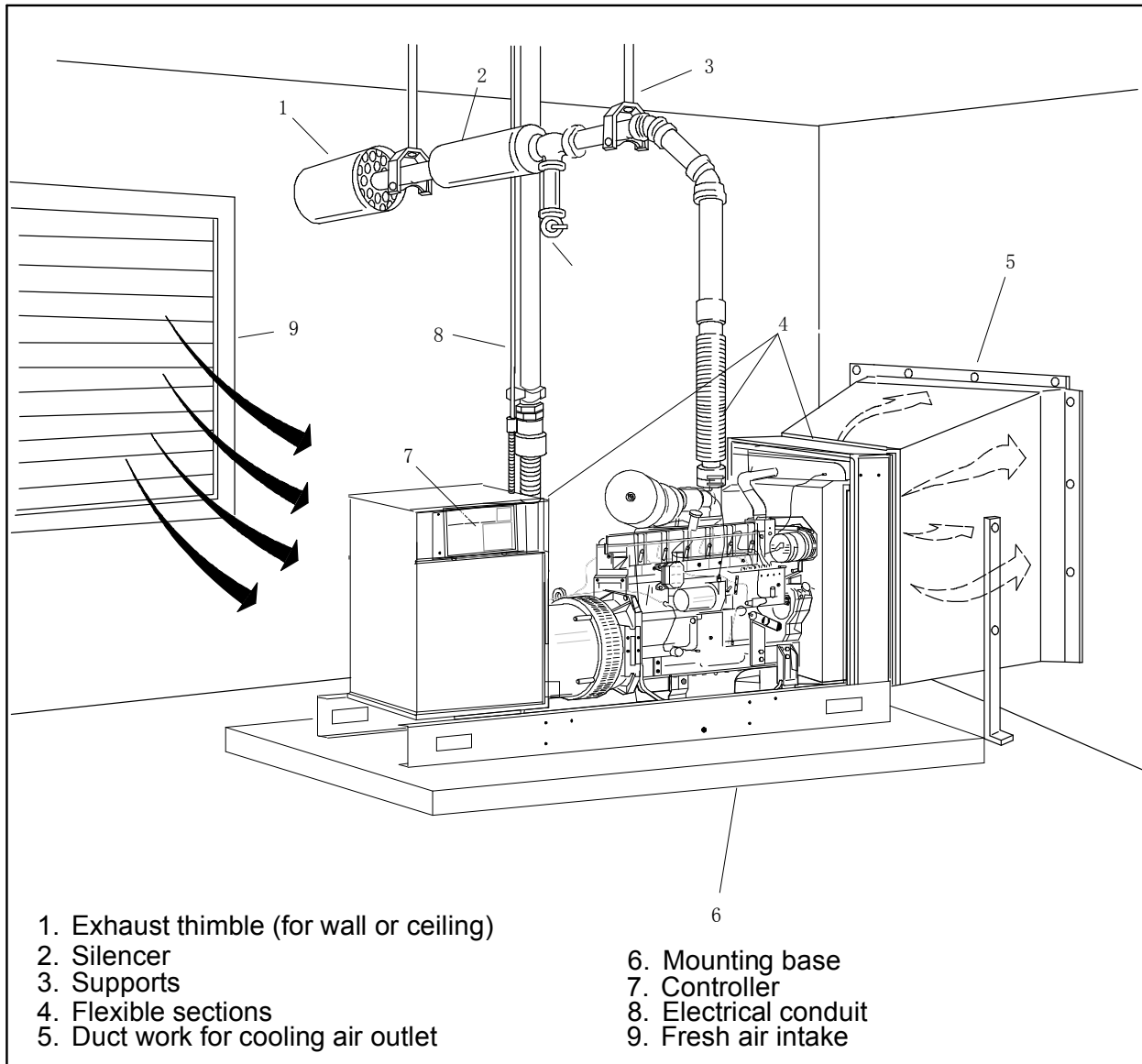

Figure2-6: Standard installation drawing

2.7 Unit-Mounted Radiator Cooling

The unit-mounted radiator is the most common cooling system for engine-driven generator sets 20 kW and larger.

2.7.1 System Features

The system's major components include an engine-driven fan and circulating water pump, a radiator, and a thermostat. The pump circulates water through the engine until it reaches operating temperature. Then the engine thermostat opens, allowing water circulation through the radiator. The thermostat restricts water flow as necessary to prevent overcooling. The fan blows air from the engine side of the radiator across the cooling surface.

2.7.2 Installation Considerations

Figure 2-7 shows a typical unit-mounted radiator installation. Note the direction of airflow and refer to the figure as

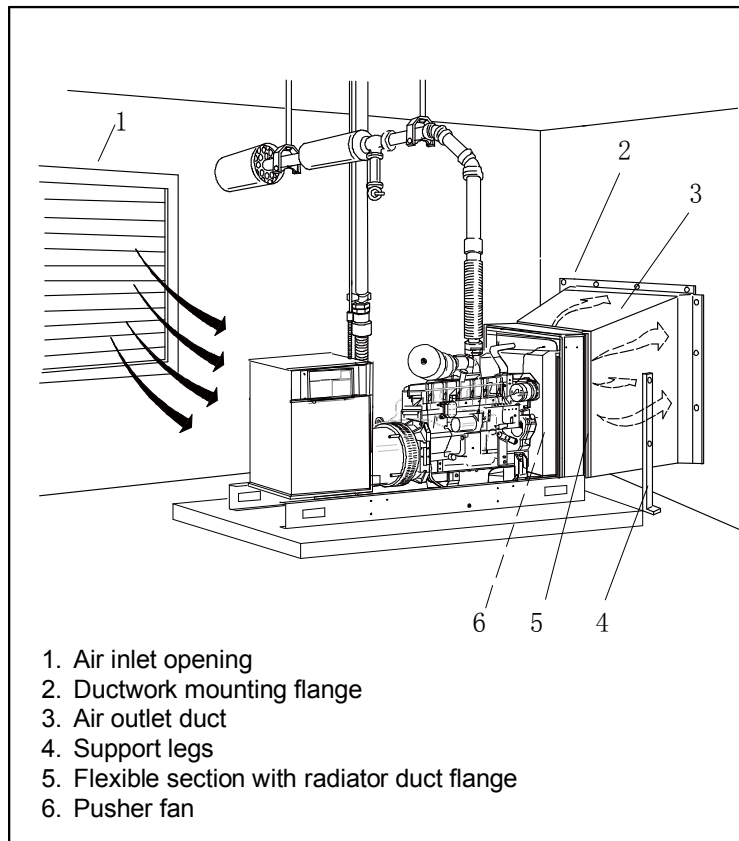

needed during installation.

Figure 2-7 Radiator-Cooled Generator Set Installation

Avoid suction fan use. The alternator airflow should move in the same direction as the engine's standard pusher fan. Using a suction fan to reverse airflow is not recommended because it may interfere with the alternator cooling airflow. This in turn reduces the maximum engine power available because higher temperature combustion air is drawn into the air cleaner.

Use ductwork to direct airflow. Direct the radiator air outside the room or enclosure using sheet metal ductwork with structural supports. Keep ductwork as short, straight, and unobstructed as possible. Combined static pressure restrictions greater than 0.12 kPa or 13 mm (0.5 in.) water column on the radiator inlet and outlet openings cause reduced airflow and contribute to overheating especially in high ambient air temperatures. Use heavy canvas, silicone rubber, or similar flexible material for the connection between the radiator duct flange and the ductwork to reduce noise and vibration transmission.

Outlet and inlet location and sizing. Size the outlet duct area 150% larger than the radiator duct flange area. Size the inlet air opening at least as large but preferably 50% larger than the outlet.

Genset Installation

Since the exhaust air of larger units is both high volume and high velocity, direct the exhaust flow away from areas occupied by people or animals.

Louver use. Design temperature-controlling louvers to prevent air inlet restrictions and air pressure reductions inside the building. Low building pressure can extinguish pilot lights on gas-fired appliances or cause problems with the building ventilation system.

Additionally, bringing large quantities of winter air into a building wastes building heat and risks frozen water pipes in normally heated spaces. Use dampers and controlled air outlet louvers as shown in Figure 4-6 to eliminate these problems and allow recovery of engine heat to reduce building heat loss. Close the louvers to the exterior and open the interior louvers when the outdoor temperature is below 18°C--21°C (65°F--70°F). Reverse the louver settings when the

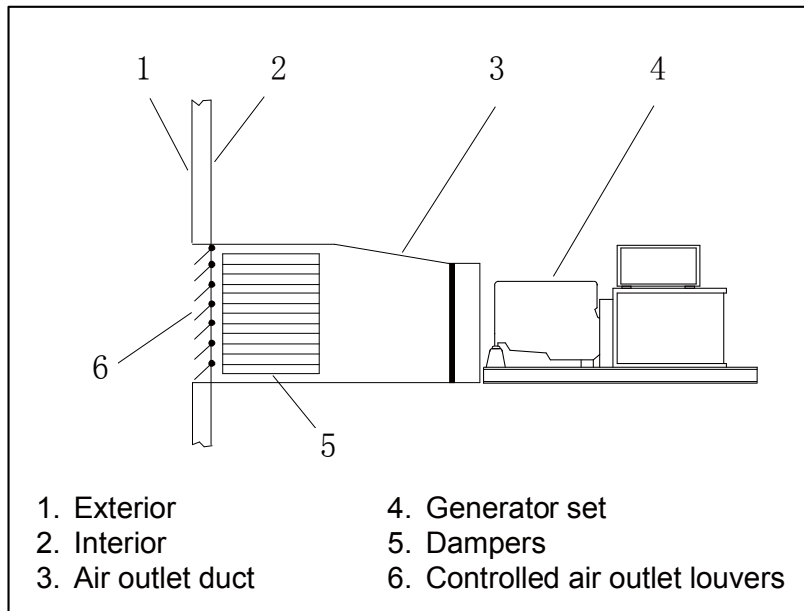

Figure 2-8
Air Control Louvers

outdoor temperature is above 21°C--24°C (70°F--75°F).

2.8 Remote Radiator Cooling

A remote radiator system allows installation of generator sets in locations where it would otherwise be difficult to bring the volume of air required to cool a unit-mounted radiator. In these systems, the engine water pump pushes coolant through a radiator mounted remotely from the generator set and, typically, in an open area. An electric motor-driven fan mounted on the radiator circulates air across the radiator's cooling fins.

In order to assess a remote radiator cooling system, the cooling system designer needs the following data. From the respective generator set specification sheet, obtain the:

- Engine jacket water flow, Lpm (gpm)
- Cooling air required for generator set based on 14°C (25°F) rise and an ambient temperature of 29°C (85°F), m³/min. (cfm)
- Maximum static (vertical) head allowable above engine, kPa (ft. H₂O) From the engine and/or radiator data sheet, obtain the:
 - Maximum water pump inlet restriction kPa (psi)
 - Maximum allowable coolant pressure differential external to engine kPa (psi)

The following subsections provide general design guidelines for a remote radiator system.

2.8.1 General

System limitations. Cooling systems are limited by radiator cap ratings. The maximum radiator operating pressure is 138 kPa (20 psi) and the maximum operating temperature is 121°C (250°F). Radiators are available for vertical or horizontal discharge. See Figure 4-7 and Figure 4-8.

Air requirements. Refer to the generator set specification sheet for radiator air and engine/alternator air requirements. Cooling air required for generator sets equipped with a remote radiator is based on a 14°C (25°F) rise and an ambient temperature of 29°C (85°F). The amount of air required to ventilate the generator set room or enclosure determines the size of the air inlet and outlet. Configure the ventilation air inlet and outlet so that air flows across the generator set.

Use a ventilating fan, if necessary, to dissipate alternator and engine heat loss.

Note: All remote radiators are sized for mounting in an open area with no additional external devices attached. Attached devices, confined installation, louvers, dampers, ductwork, or other inlet or outlet air restriction require resizing the radiator to compensate for reduced airflow.

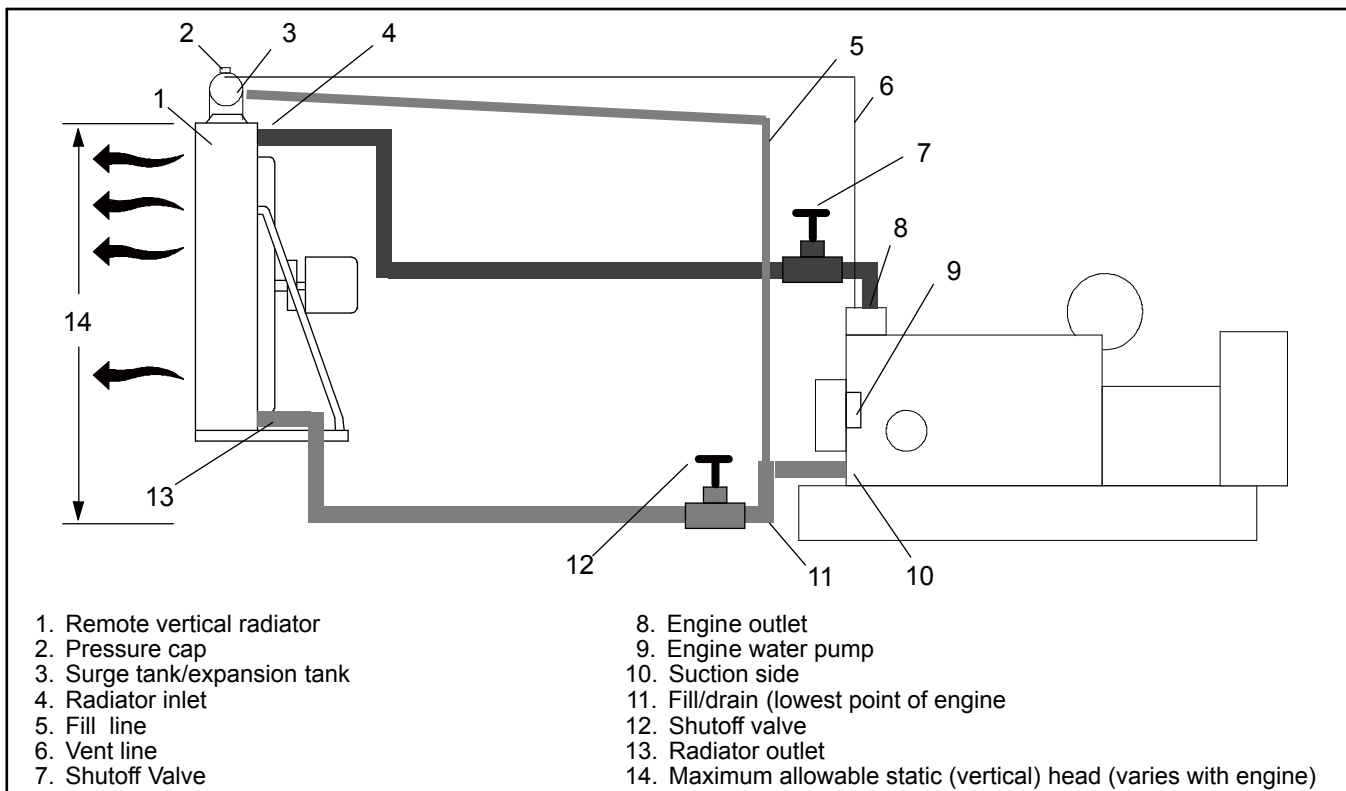

Figure 2-9 Remote Vertical Radiator System

Genset Installation

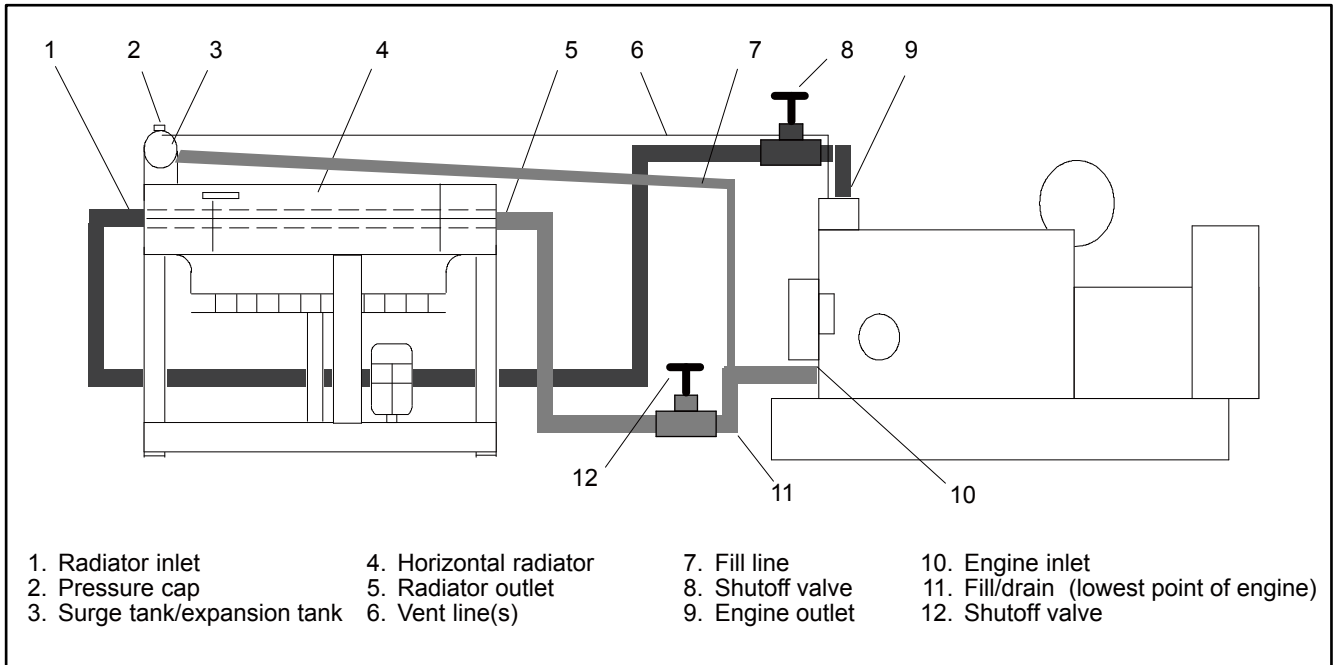

Figure 2-10 Remote Horizontal Radiator System

Static (vertical) head. If the vertical distance from the engine water pump to the radiator (known as *static head*) is within the engine manufacturer's recommendations, and the pressure drop through the piping and remote radiator does not exceed the engine manufacturer's limits, use the engine water pump to circulate water through the remote radiator. The allowable static head ranges from 5.2 m--15.2 m (17 ft.--50 ft.) and is listed on the generator set specification sheet. Exceeding the allowable static head causes excessive pressure on engine components resulting in problems such as leaking water pump seals.

Note: Size the pressure relief valve or cap to remain under the engine pressure limit.

Hot well tank/heat exchanger. When the static (vertical) head exceeds the distance stated in the specification sheet, use a hot well tank or heat exchanger and auxiliary circulating pump as shown in Figure 2-9 or Figure 2-10. Always wire the circulating pump in parallel with the remote radiator fan so that both operate whenever the generator set operates.

A partial baffle divides a hot well tank into two or more compartments. The engine pump forces heated water into the hot side, and the auxiliary pump then draws the water off and forces it into the radiator. After circulating through the radiator, coolant drains back to the cold side of the well where the engine water pump removes it. A hot well or heat exchanger also isolates head pressures from the engine.

Note: The water in the hot well tank drains into the radiator when the generator set is not running.

Note: Determine the size requirements of the remote radiator and hot well tank/heat exchanger for each application.

Do not use a standard remote radiator with a hot well tank/heat exchanger.

2.8.2 Vent Lines

Route the vent lines at a continuous upward slope from the engine connection exit to the expansion tank. Port all vent lines individually into the expansion tank above the coolant level.

Locate the vent lines in the expansion tank to prevent splash on the coolant level sensor. Thoroughly vent the systems

by

3. Exhaust System Installation

installing vent lines to all the vent points on the engine and the charge air cooler circuits including the radiator core. Refer to the installation drawings for vent points.

Size the vent line the same as the connection point on the engine. The vent lines may be slightly larger; however, vent lines sized too large will increase fill line flow and possibly reduce head pressure applied to the engine water pump inlets.

3. Exhaust System Installation

Satisfactory generator set performance requires proper exhaust system installation. Figure 3-1 and Figure 3-2 show typical arrangements of recommended exhaust systems. The following sections detail exhaust system components.

3.1 Flexible Exhaust Line

Install a section of seamless stainless steel flexible exhaust line at least 305 mm (12 in.) long within 610 mm (2 ft.) of the engine exhaust outlet. See Figure 3-1 and Figure 3-2.

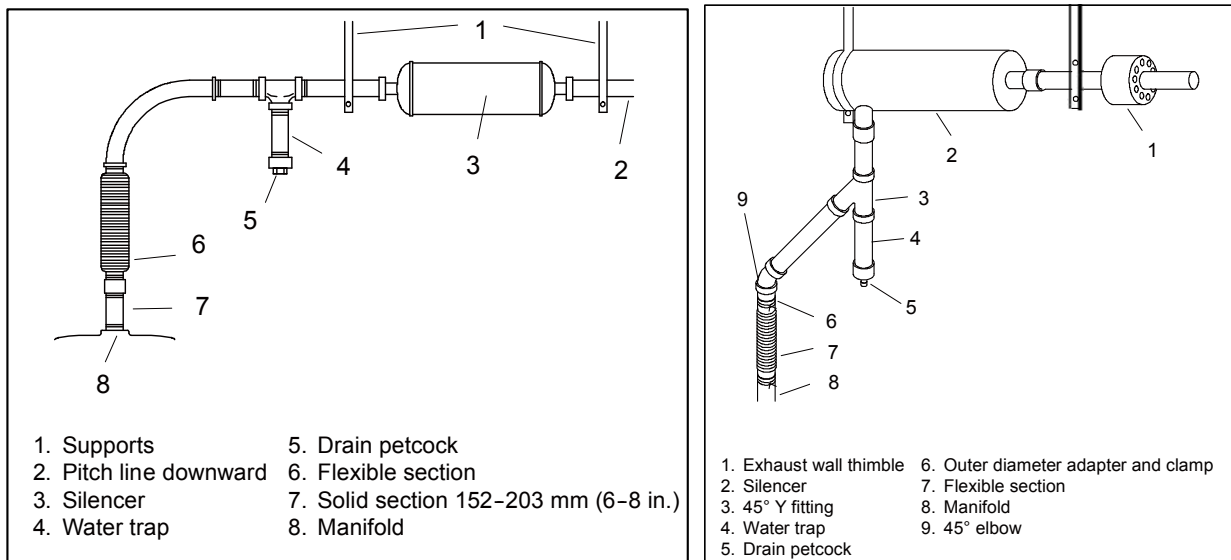

Figure 3-1 Exhaust system, End inlet silencer

Figure 3-2 Exhaust System, Side Inlet Silencer

The flexible line limits stress on the engine exhaust manifold or turbocharger. Never allow the engine manifold or turbocharger to support the silencer or exhausting piping.

Note: Do not bend the flexible section or use it to compensate for misalignment between the engine exhaust and the exhaust piping.

When using threaded flexible exhaust connectors, place a 152–203 mm (6–8 in.) length of pipe between the flexible exhaust connectors and the exhaust manifold. See Figure 5-1. The pipe reduces the temperature of the flexible connection, simplifies flexible section removal, and reduces strain on the engine exhaust manifold.

Exhaust System Installation

3.2 Condensation Trap

Some silencers are equipped with a drain pipe plug for draining condensation; see Figure 3-3. Otherwise, install a wye- or tee-type condensation trap with a drain plug or petcock between the engine and the exhaust silencer as shown in Figure 3-4. The trap prevents condensed moisture in the engine exhaust from draining into the engine after shutdown. Periodically drain collected moisture from the trap.

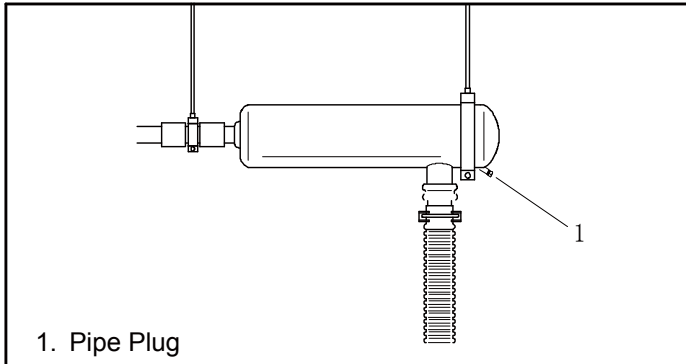

1. Pipe Plug

Silencer Condensation Drain Plug

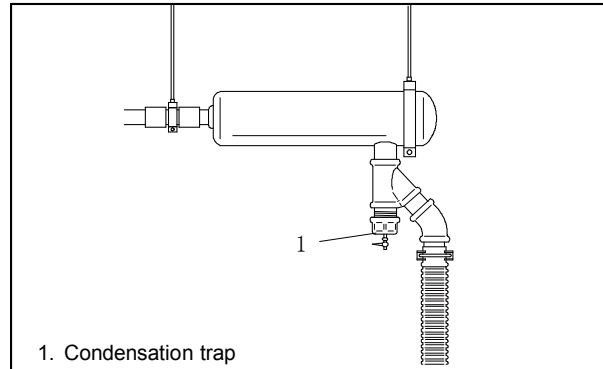

1. Condensation trap

Condensation Trap

3.3 Piping

Note: Select piping with a diameter that is the same size as, or larger than, the manifold outlet's inside diameter.

Keep exhaust lines as short and straight as possible.

Use schedule 40 black-iron pipe.

Use sweep elbows with a radius of at least three times the pipe diameter.

Use exhaust piping that conforms to applicable codes.

Support the exhaust piping securely, allowing for thermal expansion.

Insulate the exhaust piping with high-temperature insulation to reduce the heat rejected by exhaust piping and consequently the amount of ventilating air required.

In general, exhaust temperatures measured at the engine's exhaust outlet are less than 538°C (1000°F), except for infrequent brief periods; therefore, low-heat appliance standards apply. Each generator set specification sheet provides exhaust temperatures.

For units with exhaust temperatures below 538 °C (1000 °F), route the exhaust piping a minimum of 457 mm (18 in.) from combustible material, including building materials and natural surroundings. If exhaust

temperatures exceed 538 °C, the minimum distance is 914 mm (36 in.).

When planning exhaust silencer and piping placement, consider the location of combustible materials. If the proximity of the exhaust system to the combustible materials cannot be avoided, follow a regular maintenance schedule to ensure that combustible materials are kept away from the exhaust pipes after installation. Combustible materials include building materials as well as natural surroundings. Keep dry field grass, foliage, and combustible landscaping material a safe distance from the exhaust system.

3.4 Exhaust Outlet

Outlet location. Engine performance and efficiency depend on the location of the exhaust outlet. Direct the exhaust outlet away from the air inlet to prevent exhaust gases from entering the air inlet and clogging the dry-type air filter elements. Hot exhaust drawn through the radiator adversely affects engine cooling. Locate the exhaust outlet to prevent exhaust fumes from entering a building or enclosure.

Noise reduction. The exhaust outlet configuration affects the apparent noise level for people or animals in the vicinity. An upward-directed outlet seems quieter than one directed downward or horizontally. Additionally, a 30- to 45-degree angled cut at the end of a horizontal exhaust outlet pipe reduces turbulence at the outlet, thereby reducing the noise level.

3.5 Exhaust System Backpressure

Exhaust backpressure limits engine power and excessive backpressure causes serious engine damage. Excessive backpressure usually results from one or more of the following reasons:

- The exhaust pipe diameter is too small.
- The exhaust pipe is too long.
- The exhaust system has too many sharp bends.
- The exhaust silencer is too small.
- The exhaust silencer is not the correct design for the application.

Use the following procedure to verify that the installed exhaust system does not exceed the engine's maximum exhaust backpressure limit as specified in the generator set specification sheet.

Exhaust System Backpressure Calculation Procedure

Determine the total backpressure by calculating the effects of the individual exhaust system components and adding the results. Make calculations using either English or metric units. Exhaust pipe references are nominal pipe NPT (in.) sizes. The procedure shows an example with *italic* text. Calculations relate to end inlet silencers.

Note: When calculating backpressure drop for *side* inlet silencers, use the *end* inlet values shown and add

Rain cap. To prevent precipitation from entering the exhaust pipe, install a rain cap on vertical outlets. See Figure 5-5. In a climate where freezing is common, do not use a rain cap. Instead, extend the exhaust piping at least 610 mm (24 in.) beyond the roof line and create a gradual U bend at the end to direct the exhaust outlet downward. Keep the pipe outlet at least 457 mm (18 in.) from the roof to prevent hot exhaust from igniting the roof material.

Note: Do not use a rain cap in areas subject to freezing temperatures.

Generator set with enclosure. To avoid exceeding the engine manufacturer's maximum allowable backpressure specification, enclosure tail pipe extensions or attachments are not recommended.

0.75 kPa (0.25 in. of mercury or 3.4 in. of water) to backpressure calculations.

1. Select the exhaust silencer type for the application—hospital, critical, residential, or industrial. See the silencer specification sheet for definitions for each exhaust silencer type. Confirm silencer type availability for your generator set with your authorized distributor/dealer, as some generator sets do not use all four types.

Example: Determine the silencer backpressure for the recommended critical silencer on a 230 kW, 60 Hz diesel generator set.

2. Refer to the generator set specification sheet for:
 - a. Engine exhaust flow at rated kW in m³/min. (cfm)
Example: 57.5 m³/min. (2030 cfm)
 - b. Maximum allowable backpressure in kPa (in. of Hg)
Example: 10.2 kPa (3.0 in. Hg)

4. Fuel System Installation

Comply with applicable state and local codes when installing any fuel system.

4.1 Main Tank

The main components of a typical diesel fuel system are a main fuel storage tank, a day tank, fuel lines, and an auxiliary fuel pump. See Figure 4-1.

Storage. Because it is less volatile than gas or gasoline, diesel fuel is safer to store and handle. Regulations for diesel storage tank placement are less stringent than the regulations for gas or gasoline storage. In some locations, large main tanks are permitted inside the building or enclosure.

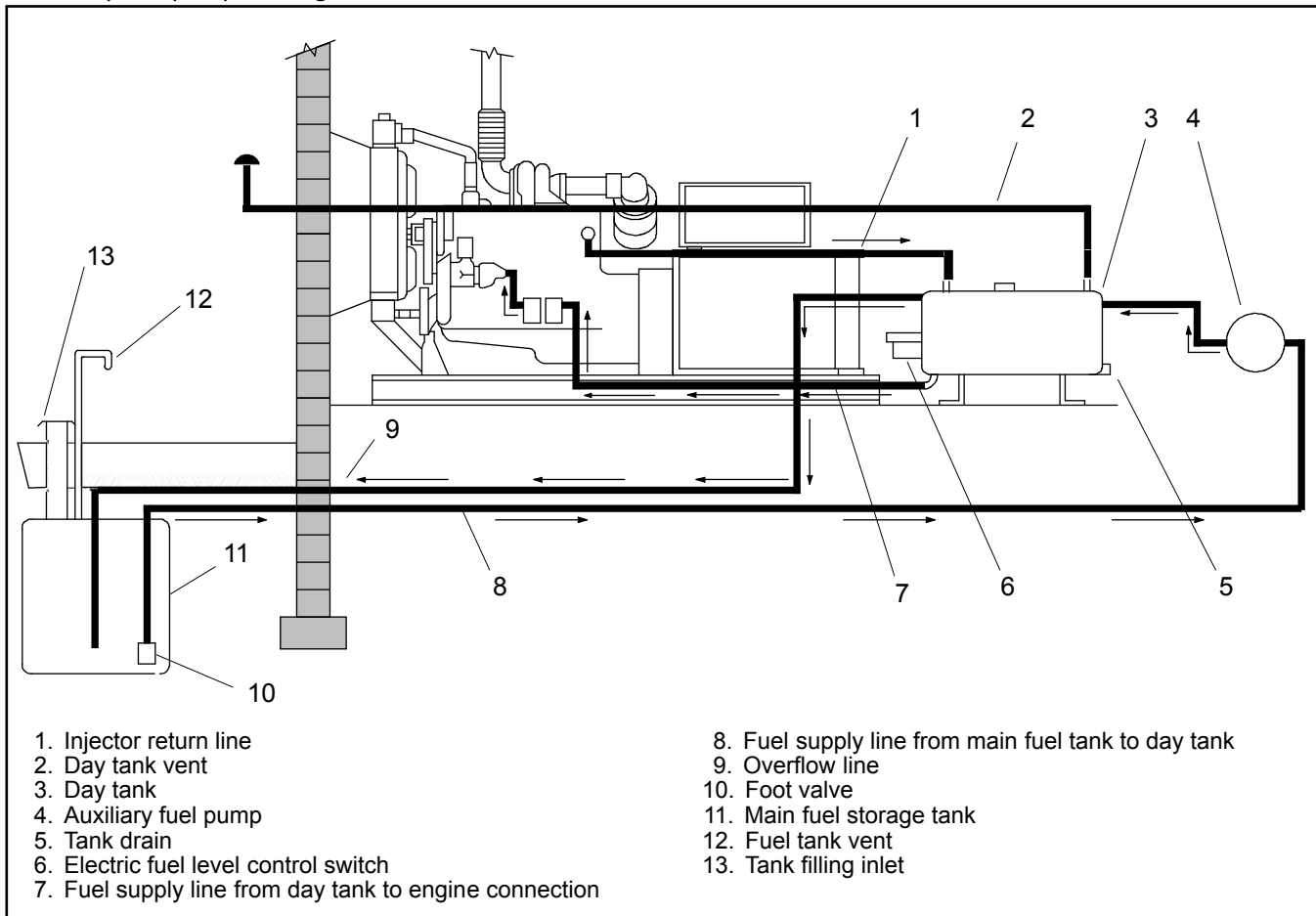

Figure 4-1 Diesel Fuel System

4.2 Tank location

Locate fuel storage tanks above ground or bury them underground in accordance with applicable codes. Figure 4-2 shows a commonly used above-ground subbase tank contained in the generator set mounting base.

Provide easy access to fuel filters and sediment drains for regular and frequent service. Clean fuel is especially important to diesel engines, which have easily clogged fuel injectors and pumps.

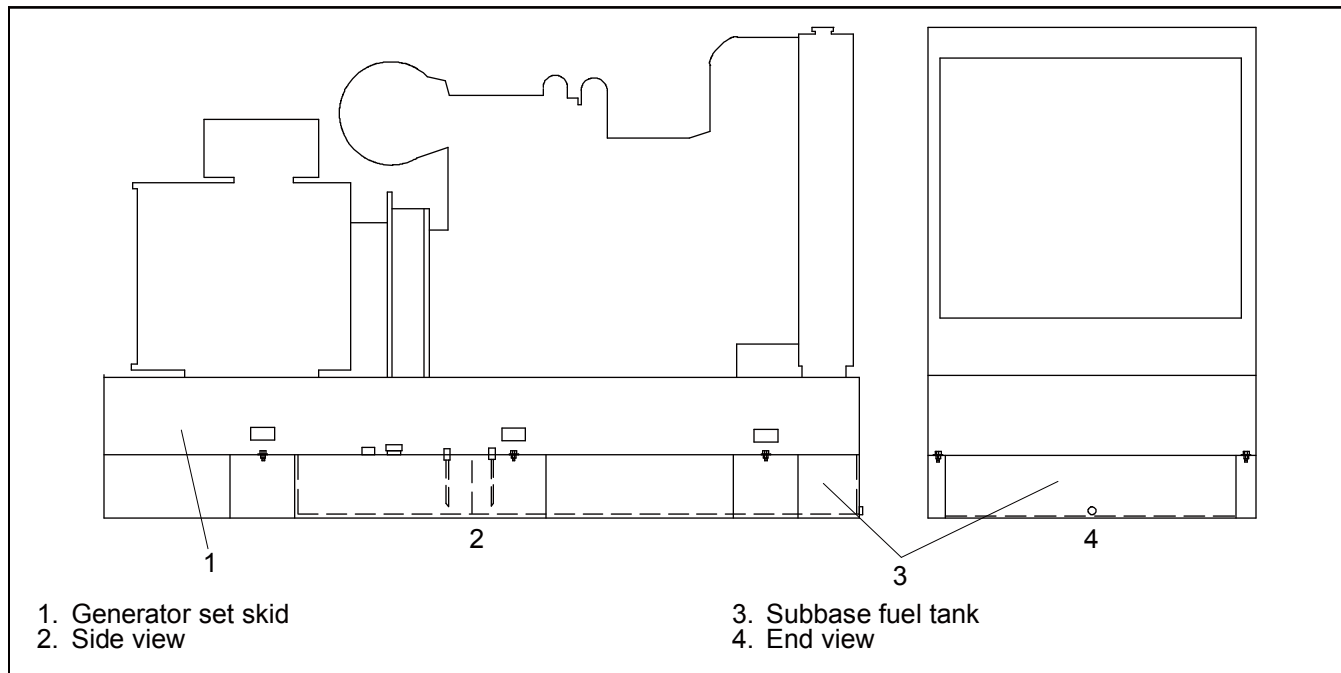

Figure 4-2 Subbase Fuel Tank

Tank size.

Codes requiring standby power often specify a minimum onsite fuel supply. Such requirements are included in NFPA 70, National Electrical Code, and NFPA 99, Standard for Health Care Facilities. Diesel fuel deteriorates if stored for more than one year; therefore, size the tank to ensure that regular generator set exercising will use the tank's contents within one year. If there are no applicable code requirements, the manufacturer recommends a tank sized for eight hours of operation at rated load. Refer to the generator set specification sheet for fuel consumption data.

Tank venting. Vent the main fuel tanks to allow air and other gases to escape to the atmosphere without allowing dust, dirt, and moisture to enter the tank.

Fuel expansion. Never fill the tank more than 95% full to allow for fuel expansion. On overhead main tanks, use a fuel shutoff solenoid to prevent hydraulic lock or tank overflow caused by excessive static head fuel pressures.

Fuel alternatives. Most diesel engines operate satisfactorily on No. 2 domestic burner oil available in most parts of the US. If the site heating system is oil-fired, consider supplying the engine with fuel from the same tank used for heating oil to reduce costs and to ensure a continually fresh fuel supply for the engine. This practice necessitates that the fuel oil meets the engine manufacturer's minimum requirements for wax point, pour point, sulfur content, and certain number as these factors influence cold weather starting and generator set power output. When supplying multiple applications from the same main fuel tank, provide each with a separate supplyline.

Fuel system Installation

4.3 Day Tanks

(100°F) and are subject to damage if operated with fuel temperatures above 60°C (140°F), a day tank providing The terms day tank and transfer tank are interchangeable. Having a day tank adjacent to the engine allows the engine fuel transfer pump to easily draw fuel during startup and provides a convenient location to connect fuel injector return lines. See Figure 4-3. Connect a float-switch-controlled solenoid antiphon valve or a float valve to prevent siphoning fuel from the main storage tank if the main tank fuel level is above the day tank inlet.

Tank size. Standard tanks are available in sizes from 55--1555 L (14.5--410 gal.) without integral electric fuel transfer pumps. Because engines are at least four hours of fuel consumption should be used to provide enough capacity to cool the fuel returning from the engine. If smaller day tanks are used, the generator set manufacturer may recommend installing a fuel cooler or routing engine fuel return lines to the main storage tank. See Figure 4-3.

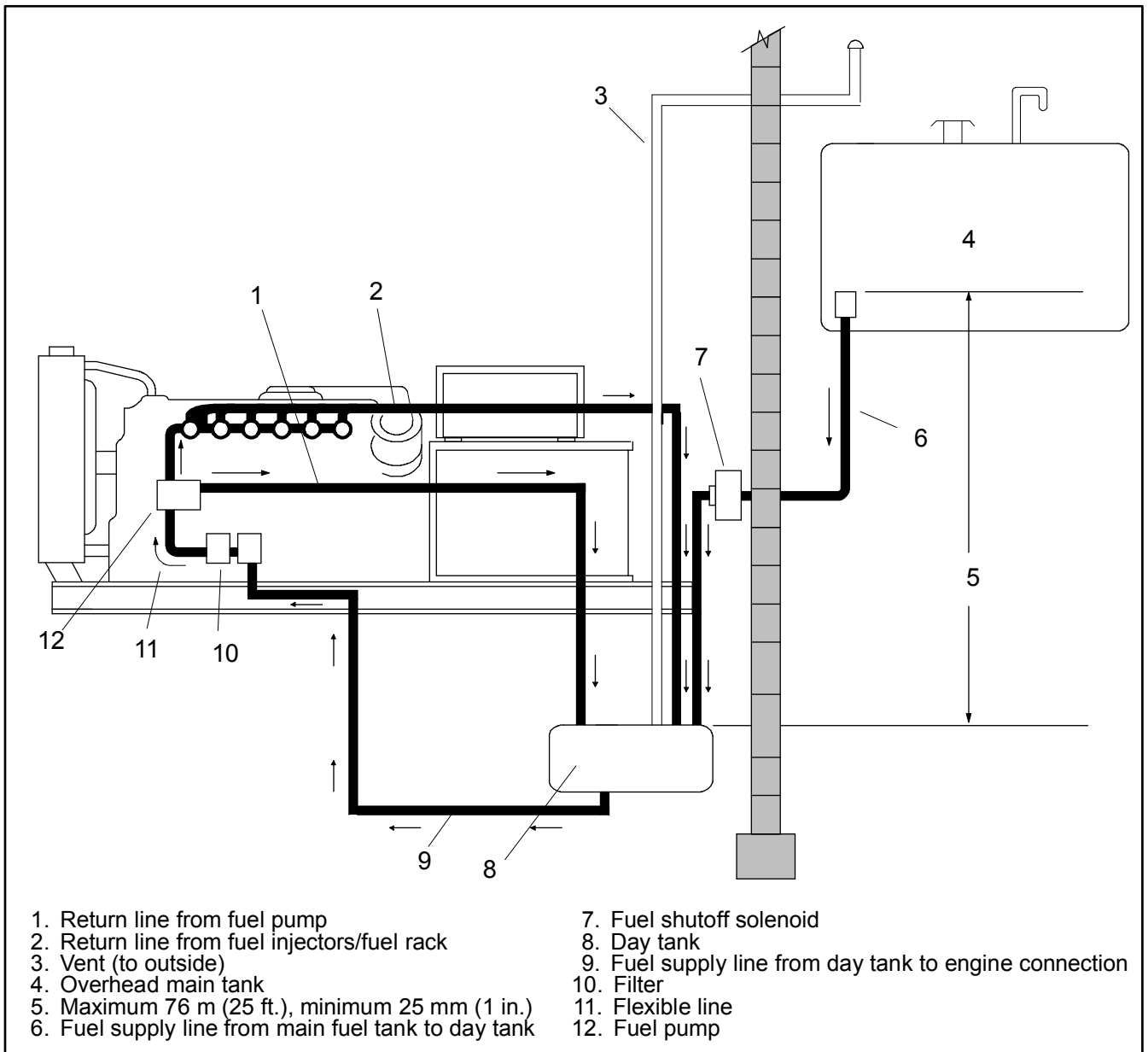

Figure 4-3 Diesel Fuel System with Overhead Main Tank and Day Tank

Fuel system Installation

Optional equipment includes fuel level gauges, manual priming pumps, float switches for pump control, float valves, rupture basins, and low level alarms. Remove the plastic shipping plugs and install metallic pipe plugs in all unused fuel tank ports to provide a liquid-tight seal. subject to fuel temperature deration above 38°C.

4.4 Fuel Lines

The following items describe fuel line selection and application. Never use the fuel piping or fuel line clamps to ground any electrical equipment.

Line type. Use Schedule 40 black-iron pipe, steel tubing, or copper tubing for diesel fuel systems. Diesel fuel reacts adversely with galvanized tanks and piping, producing flaking sediment that quickly clogs filters and causes fuel pump and fuel injector failure. Ensure that any flexible fuel lines used are approved for diesel fuel.

Line size. Use the smallest diameter fuel line that still delivers enough fuel to the engine with an acceptable pressure drop of 6.9 kPa (1.0 psi). Using oversize piping increases the chance of air introduction into the fuel system during engine priming, which increases the potential for fuel pump damage and hard starting.

Flexible connectors. Use flexible connections spanning a minimum of 152 mm (6 in.) between the stationary piping and the engine fuel inlet connection.

Return lines. A diesel system delivers more fuel to the

injectors than the engine uses; therefore, a system has one supply line from the fuel tank and at least one return line from the fuel injectors. Size the fuel return lines no smaller than the fuel supply lines.

Route the return fuel line to either the day tank or the main storage tank. Place the return lines as far away from the pickup or fuel dip tube as possible to prevent air entry and to keep warm fuel from being reintroduced to the engine. If fuel lines are routed to the day tank, note the day tank size requirements in Section 4.3, Day Tanks.

A properly designed fuel return line is unrestricted and as short as possible, and it allows gravity return of fuel to the storage tanks. In installations where gravity return is not possible, obtain approval of the design from the generator set supplier based upon the engine's specifications before installing a fuel system with static head pressure on the return lines. Fuel return line restriction can cause engine hydraulic lock or uncontrollable over speed on some systems.

4.5 Auxiliary Fuel Pumps

Primary, engine-driven fuel pumps typically develop a maximum of 48 kPa (7 psi) pressure and draw fuel to approximately 1.2--1.4 m (4--5 ft.) vertically or 6 m (20 ft.) horizontally. When the main tank is located a greater distance from the engine or for a more reliable fuel system, use an auxiliary pump alone or in connection with a day tank. See Figure 6-3. Limit auxiliary fuel pump pressure to approximately 35 kPa (5 psi).

Use a shutoff solenoid valve wired into the engine run circuit or a check valve to help keep the fuel line primed. Install the check valve on the outlet side of the auxiliary fuel pump to minimize inlet restriction.

Auxiliary fuel pump options. On engines using less than 38 L (10 gal.) of fuel per hour (approximately 100 kW or less), connect an engine starting battery-powered electric fuel transfer pump in series with the engine-driven transfer pump. Locate the electric pump nearer to the fuel tank than to the engine. An auxiliary pump located at the fuel tank approximately

doubles the horizontal and vertical distance limits of a single engine-driven pump.

On engines using more than 38 L (10 gal.) of fuel per hour or when drawing fuel more than 1.8 m (6 ft.) vertically or 12 m (40 ft.) horizontally, use an electric motor-driven positive displacement pump with a day tank and float switch. Electrically connect the fuel pump to the transfer switch load side for maximum reliability. This type of pump can typically lift fuel 5.5 m (18 ft.) or draw it horizontally up to 61 m (200 ft.).

Where vertical runs exceed 5.5 m (18 ft.) or horizontal runs exceed 61 m (200 ft.), remote-mount the pump adjacent to the fuel storage tank. This type of installation allows these pumps to push fuel over 305 m (1000 ft.) horizontally or more than 31 m (100 ft.) vertically and deliver adequate fuel for generator sets up to 2000 kW. Always connect a positive-displacement pump directly to a day tank and float switch to protect the engine fuel system from excessive fuel pressures.

5. Genset Operations

5.1 General Instructions

Because of all major components and accessories of Company series diesel genset are from the world-renowned manufacturers, and the O.E.M manufacturer has rich assembling experience, advanced production technology and strict testing process before delivery, if the user is in full accordance with requirements in this operation manual, Company series diesel genset can ensure the long term normal use.

Company series diesel genset are equipped with an advanced electrical control system, mainly with the following types: DSE3110 control system, DSE7320 auto control system and DSE8610 intelligent parallel monitoring system. With these systems, users can operate the diesel genset manually、 automatically or monitoring. They all have auto fault alarm and protection functions. That is when the running genset has failure, The control system will automatically send out warning signals and even shut down to ensure the genset works under normal condition at any time and immediately take relevant treatment.

5.2 Start the genset

The following steps particularly present the preparation works, initial start/stop and normal start/stop.

5.2.1 Preparation before starting

(1). Overall inspection

Turn off switches on control panel before inspection.

- ◆ Re-clean and inspect the genset room, ensure there is no inflammable and explosive material is around and ensure there is smooth air in and out.
- ◆ Complete inspection to ensure correct, reliable and non-aging phenomenon with the electrical and control part.

Do not short circuit output electrode of the battery.

- ◆ Check the reliability of the fasteners and throttling system to ensure all the operating mechanisms are flexible, portable and reliable. Inspect belts of Water pump, battery charger and fan are in pretention condition.
- ◆ Clean the surface of the genset, ensure no leakage of cooling liquid, fuel and engine oil.

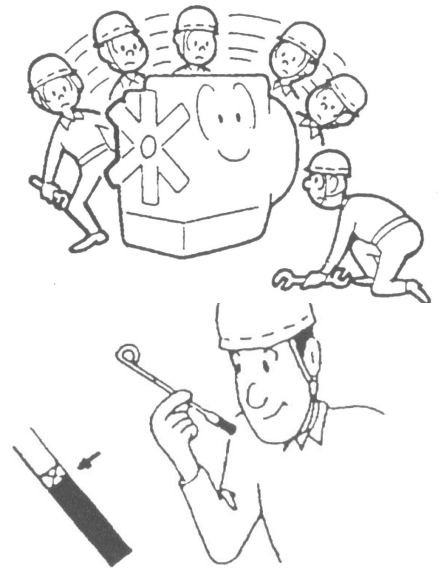

(2). Inspect engine oil level

Inspect and ensure the engine oil level is between the highest and lowest level, and it is better closing to but not exceeding the highest level.

(3). Inspect fuel level

- ◆ Check the diesel in the fuel tank, refuel it if necessary.

Warning! Not to infuse unfiltered fuel into the engine.

- ◆ Check and ensure there is no air in the fuel oil loop. If there is, unscrew the bleed screw of the fuel filter, use manual pump pumping the fuel to the bleed screw and injecting, tighten the bleed screw at last.

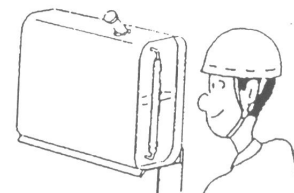

(4). Coolant level

It is better be 5cm under the covering cap to ensure no blocking in the external of the radiator.

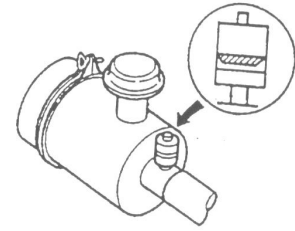

(5). Inspecting air filter

Check the indicator of air filter. Replace the air filter if the indicator is red.

Important!

Running the engine without air filter is prohibited.

(6). Inspect electric quantity of the battery.

Should recharge to full condition if it can't reach starting requirements.

Important! Only use the fuel and engine

oil recommended in this manual.

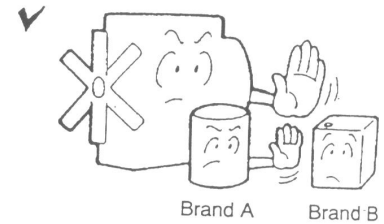

5.2.2 Start the genset

The following steps can be used to debug/initial start the diesel genset which is equipped with DSE3110 control panel, or the initial start after a period of time's breakdown of the genset failure. Regarding the details of DSE3110 and other control systems, please refer to the next section of "Control Module Operation Guide", or consult Company.

(1). Starting genset

- ◆ Finish all the inspection work before starting.
- ◆ Connect the battery to the genset, first with positive pole, then with negative pole
- ◆ Start diesel genset



Warning! Load connection and operation should be conducted by qualified and experienced technicians

Important! Start up with load is prohibited

If the genset can't be started normally the first time, then it will try to auto start every 10 seconds. If it still can't achieve normal start after 3 times' consecutive start, the genset start failed. The genset should be stopped to check the reason for starting failure, or refer to the "Engine Operation Instruction" for getting more information. Before starting the diesel genset again, make sure the failure has been excluded.

(2). Genset operation

- ◆ Check the unnormal noise or vibration of the genset
- ◆ Check if there is leakage problem for the three liquid (coolant, fuel and oil) & air exhaust system.

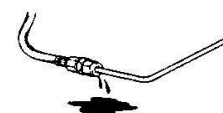

Genset Operations

Check if there is any unusual indication for the meter of control system, especially high water temperature or low oil pressure, the oil pressure should be in normal condition after normal start the genset for 10 seconds.

- ◆ Check the output voltage and frequency from the control panel. Because genset has been well adjusted in factory, the output voltage of the genset should be in normal range. For genset with mechanical speed governor, the frequency should be close to 52Hz under no-load condition; For genset with electronic speed governor or ECM speed governor, the frequency should be close to 50Hz under no-load condition.
- ◆ Adjustment should be conducted by a qualified electrician or technician, the output voltage of the alternator can be adjusted by a potentiometer in the AVR which is in the terminal box of the alternator. For details, please refer to "Alternator installation and maintenance manual".
- ◆ When using phase checker to inspect the phase, pay attention to connect the phase meter to one side of the circuit breaker. The checking should be done by qualified technicians.
- ◆ Every starting, stopping or one hour running, record the operating parameter of the genset one time.
- ◆ Only after making sure that the electrical equipment allows with the power supply from the genset, under the supervision of the distribution personnel, then the circuit breaker closing or ATS end distribution operation can be done.
- ◆ Load of genset can not exceeding the rated value.

Cautious! Running continuously under no-load condition

For over half an hour or below 30% load is prohibited. This is to avoid the leakage of lube oil.

Danger! No dismantling any components of the genset when it is running.

Danger! Do not stretch hands to the area under fan cover or any place which has relative motion.

Warning! Don't attempt to touch the surface of exhaust pipe, turbo charger, high temperature coolant or heater since there are possibilities of scalding people.

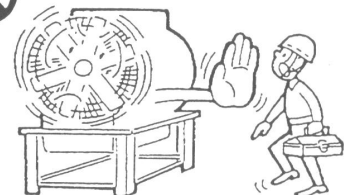

5.3 Stop the genset

5.3.1 Stop the Genset

Select Stop/Reset Button to stop the genset.



Important! Without exceptional circumstance, the genset should not be running for about 5min without any load before stopping.

5.3.2 Emergent stop

Emergent stop the genset with anyone of the following problem:

- ◆ Low engine oil pressure, failure light is red;
- ◆ High temperature with cooling water, failure light is red
- ◆ When genset rotate speed over 1650rpm (namely frequency meter indicates over 55Hz)
- ◆ When the genset has sharp and unusual knocking noise;
- ◆ When parts damaged, and may cause damage to any component of the genset.

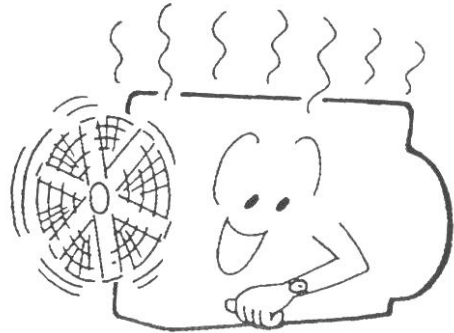

- ◆ When the moving parts such as cylinder, piston, bearing bush or governor is stuck;
- ◆ When the output voltage is over the full-scale reading in the meter;
- ◆ When the fire, leakage of electricity or other natural hazard may happen or it is dangerous for the genset and operation staff.

At this moment, press the emergency stop button, which will switch off genset and disconnect all load from genset. At the meantime, the red “emergency stop” indicator lights. The button should be again rotated out to relieve alarm signal.

When the genset is running normally or in the process of supplying power for the equipment, it is suggested that do not press “Emergency stop” button if there is no special emergency happens.

5.3.3 After stop

- ◆ Check if there is leakage of engine or genset room;
- ◆ Shut down fuel valve
- ◆ If the genset needs to stop using for a period, turn off the main control panel power switch.
- ◆ Release all the fuel and cooling water, and regularly charge the battery in accordance with the maintenance rule.
- ◆ When the ambient temperature is below 5°C, after the genset stops, it must take antifreeze measures to avoid the body and the water tank been frost and cracked.

5.4 Start genset under cold environment

Preparation works must be done when the genset is started in cold environment. Using winter fuel which is applicable to local temperature (qualified brand). This will decrease the danger of emerging waxiness sediment in fuel injection system. When the ambient temperature is extremely low, we suggest using fuel heater which heats the coolant of the engine.

Important! Ensure to fill antifreeze to the cooling system.

Battery must be in good condition. Low temperature may reduce battery capacity. The larger capacity battery should be considered base on actual situation.

6. Control Module Operation Guide

6.1 DSE3110 control system

6.1.1 DSE3110 Control panel

The following sections explain the function and meaning of the **various buttons** on the module.

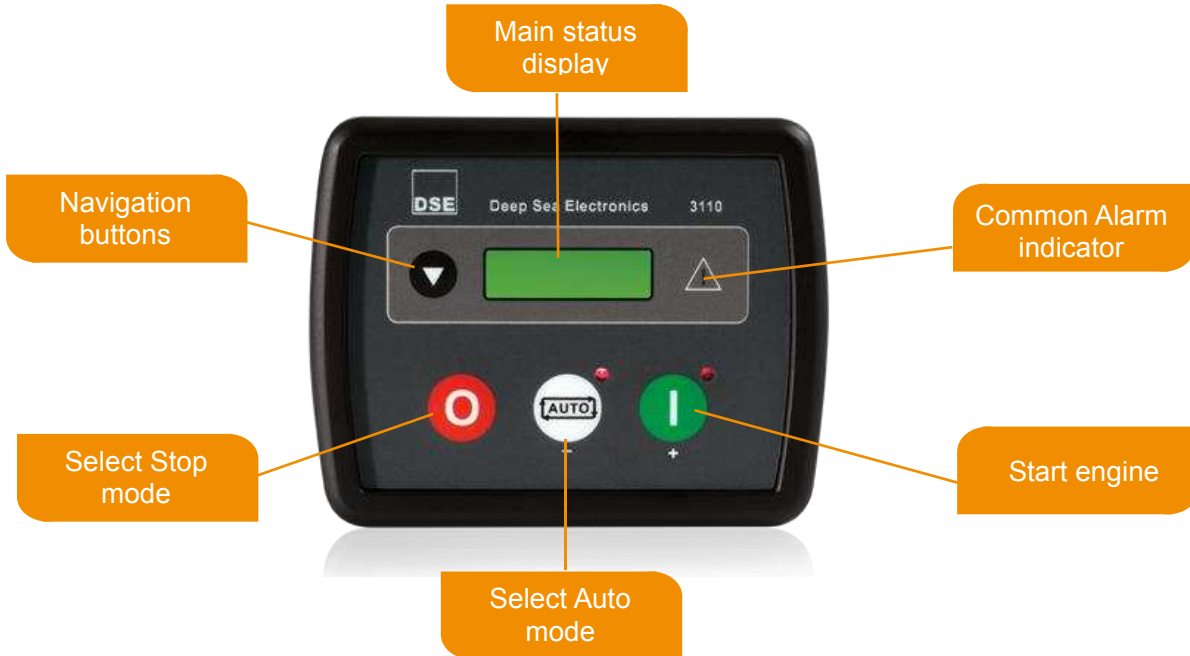

6.1.2 Description of DSE3110 control

- ◆ The DSE3110 can be utilized as a Manual or Auto Start Module for single generating set applications and forms part of DSE's next generation of control modules. The module has been designed to work with electronic and non-electronic engines providing advanced engine monitoring and protection features.
- ◆ The DSE3110 includes a back-lit LCD display which clearly shows the status of the engine at all times. The module monitors engine speed, frequency, voltage and run hours and also displays the warning and shutdown status of the engine.

6.1.3 Start the engine



6.1.4 Stop the engine



6.1.5 Viewing the instruments

The user can **switch** display the different pages of information by repeatedly operating the scroll  button. Once selected, the page will remain on the LCD display until the user selects a different page or after an extended period of inactivity, the module will revert to the status display.



When scrolling manually, the display will automatically return to the status page if no buttons are pressed for the duration of the configurable LCD Page Timer.

If an alarm becomes active while viewing the status page, the display shows the Alarms page to draw the operator's attention to the **alarming circumstance**.

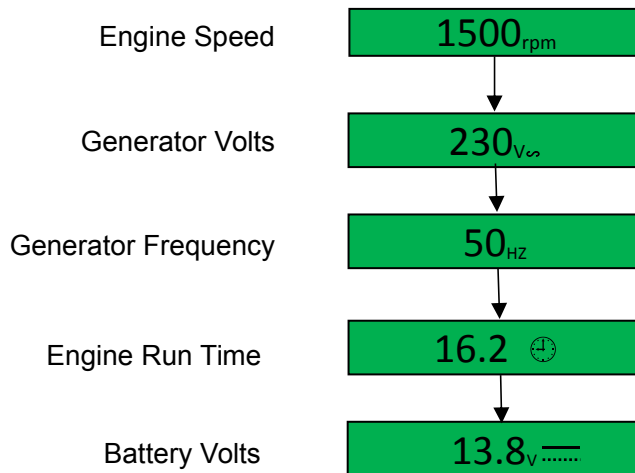
Page order



6.1.6 Automatic mode of operation

Activate auto mode by pressing the  pushbutton. The  icon is displayed to indicate. Generator sets are under auto standby status. Now the external signals (resistive contact signal) enter effective, generator sets start automatic. When the internal signals disconcert, Genset cooling and shut down, time is 60s(cooling time can self- set up). If the user find that the genset is working abnormally, press  to shut down/reset key to close. Auto Mode operation if no alarms. Auto mode will allow the generator to operate fully automatically, starting and stopping as required with non-user intervention.

Control Module Operation Guide

6.1.7 DSE3110 accessing the front panel configuration editor



Ensure the engine is at rest and the module is in STOP mode by pressing the Stop/Reset  button.

Press the Stop/Reset  and Down  buttons simultaneously.

The configuration icon  is displayed on the screen, along with the first configurable parameter.

Editing a parameter



Press  to select the required 'page' as detailed in the configuration tables.

Press  (+) to select the next parameter or  (-) to select the previous parameter within the current page.

When viewing the parameter to be changed, press the  button. The value begins to flash.

Press  (+) or  (-) to adjust the value to the required setting.

Press  to save the current value, the value ceases flashing.

Press and hold the  button to exit the editor, the configuration icon  will disappear from the display.

6.1.8 DSE3110 detailed in the configuration tables:

CONFIGURATION PARAMETERS MODULE (Page 1)		
101	Contrast	000 (%)
102	RESERVED	
103	RESERVED	
104	Lamp test at startup	On (1), Off (0)
105	Power save mode enable	On (1), Off (0)
106	Protected start enable	On (1), Off (0)
107	Power up into Auto mode	On (1), Off (0)
108	Oil Pressure in PSI	On (1), Off (0)
109	Display Volts in Ph-Ph	On (1), Off (0)

Control Module Operation Guide

CONFIGURATION PARAMETERS TIMERS (Page 5)

501	Remote Start Delay	0:00
502	Preheating timer	0:00
503/4	RESERVED	
505	Smoke limiting	0:00
506	Smoke limiting off	0:00
507	RESERVED	
508	Warm up time	0:00
509	Return Delay	0:00
510	Cooling time	0:00
511	ETS Solenoid Hold	0:00
511-514	RESERVED	
515	Breaker trip pulse	0:00
516	Breaker close pulse	0:00

CONFIGURATION PARAMETERS GENERATOR (Page 6)

601	Alternator Fitted	On (1), Off (0)
602	Alternator Poles	0
603-604	RESERVED	
605	Under Voltage trip enabled	On (1), Off (0)
606	Under Voltage trip level	0 V
607	Loading Voltage	0 V
608	Over Voltage trip level	0 V
609	Under frequency trip enabled	On (1), Off (0)
610	Under frequency trip level	0.0 Hz
611	Loading frequency	0.0 Hz
612	Nominal frequency	0.0 Hz
613	Over frequency trip enabled	On (1), Off (0)
614	Over frequency trip level	0.0 Hz
615	AC System	0-4

Control Module Operation Guide





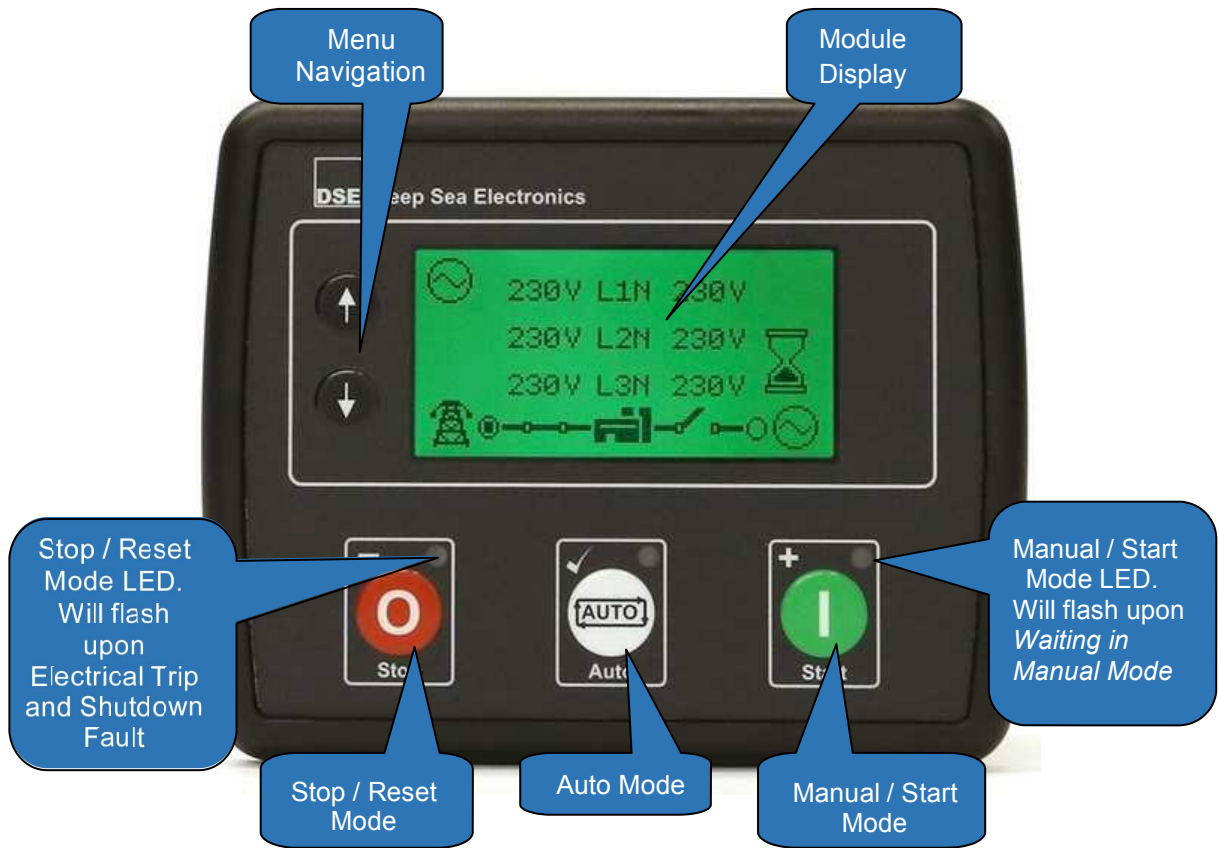

6.2 DSE4520 Control system

6.2.1 DSE4520 Control panel





The following sections explain the function and meaning of the various controls on the module.



6.2.2 DSE4520 control push buttons

Icon	Description
	<p>Stop/Reet Mode</p> <p>This button places the module into its Stop/Reset Mode . This clears any alarm conditions for which the triggering criteria has been removed. If the engine is running and the module is put into Stop/Reset Mode , the module automatically instructs the generator off load ('Close Generator Output' becomes <i>inactive (if used)</i>) and place the mains on load ('Close Mains Output' becomes <i>active (if used on DSE4520 MKII)</i>). The fuel supply de-energises and the engine comes to a standstill. Should any form of <i>start signal</i> be present when in Stop/ResetMode  the generatorremains at rest. For further details, see the more detailed section of <i>Operation</i> elsewhere in this manual.</p>
	<p>Auto Mode</p> <p>This button places the module into its Auto Mode . This mode allows the module to control the function of the generator automatically. The module monitors numerous start requests and when one has been made, the set is automatically started. Once the generator is available, the mains is taken off load ('Close Mains Output' becomes <i>inactive (if used on DSE4520 MKII)</i>) and the generator is placed on load ('Close Generator Output' becomes <i>active (if used)</i> and 'Delayed Load Output 1, 2, 3 & 4' becomes <i>active (if used)</i>).</p> <p>Upon removal of the starting signal, the module starts the <i>Return Delay Timer</i> and once expired, takes the generator off load ('Close Generator Output' becomes <i>inactive (if used)</i> and 'Delayed Load Output 1, 2, 3 & 4' becomes <i>inactive (if used)</i>) and places the mains on load ('Close Mains Output' becomes <i>active (if used on DSE4520 MKII)</i>). The generator then continues to run for the duration of the <i>Cooling Timer</i> until it stops. The module then waits for the next start event.</p> <p>For further details, see the more detailed section of <i>Operation</i> elsewhere in this manual.</p>

Control Module Operation Guide

Icon	Description
	<p>Manual/Start Mode</p> <p>This button starts the generator and runs it off load. To place the generator on load digital inputs are required to provide the loading/unloading instruction.</p> <p>If the engine is running off-load in Manual/Start Mode  and a <i>Remote Start Signal</i> becomes present, the module automatically instructs the changeover device to take the mains off load ('Close Mains Output' becomes inactive (if used on DSE4520 MKII)) and place the generator on load ('Close Generator Output' becomes active (if used) and 'Delayed Load Output 1, 2, 3 & 4' becomes active (if used)).</p> <p>Upon removal of the <i>Remote Start Signal</i>, the generator remains on load until Stop/Reset Mode  or Auto Mode  are selected.</p> <p>For further details, see the more detailed section of <i>Operation</i> elsewhere in this manual.</p>
	<p>Menu Navigation</p> <p>Used for navigating the instrumentation, event log and configuration screens.</p>

Control Module Operation Guide

6.3 DSE7320 Control system

6.3.1 DSE7320 Control panel

The following sections explain the function and meaning of the various controls on the module.

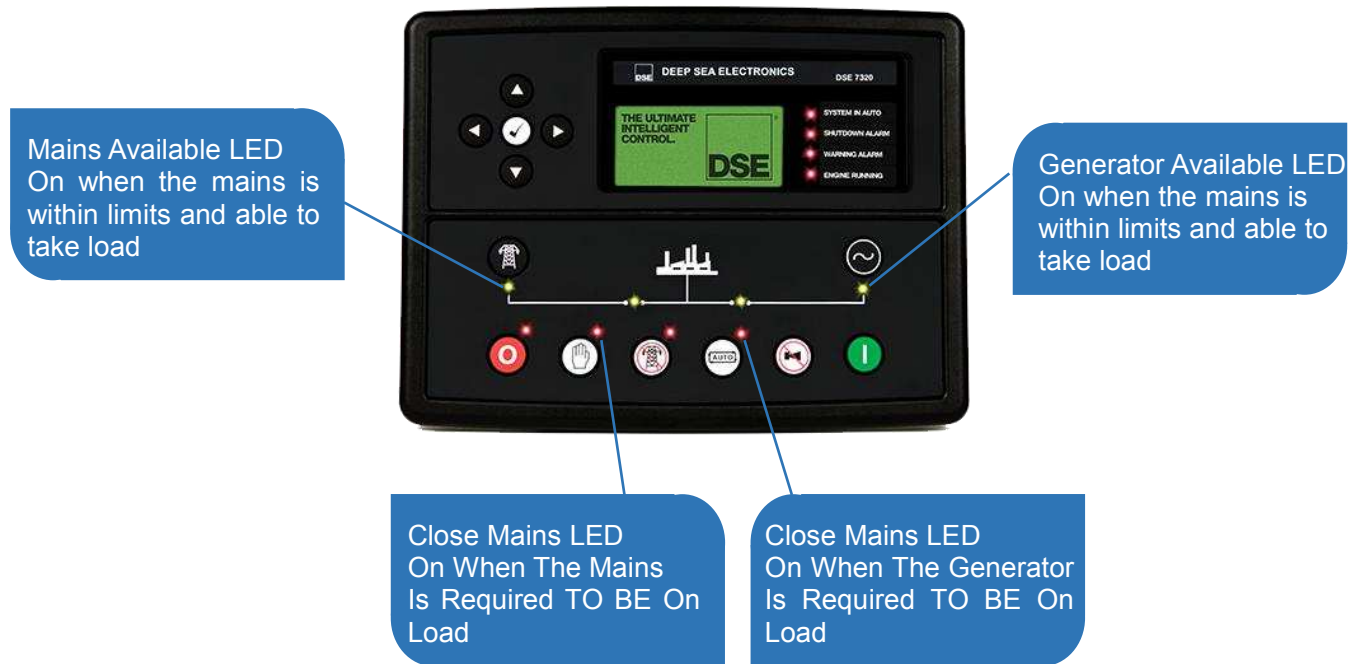
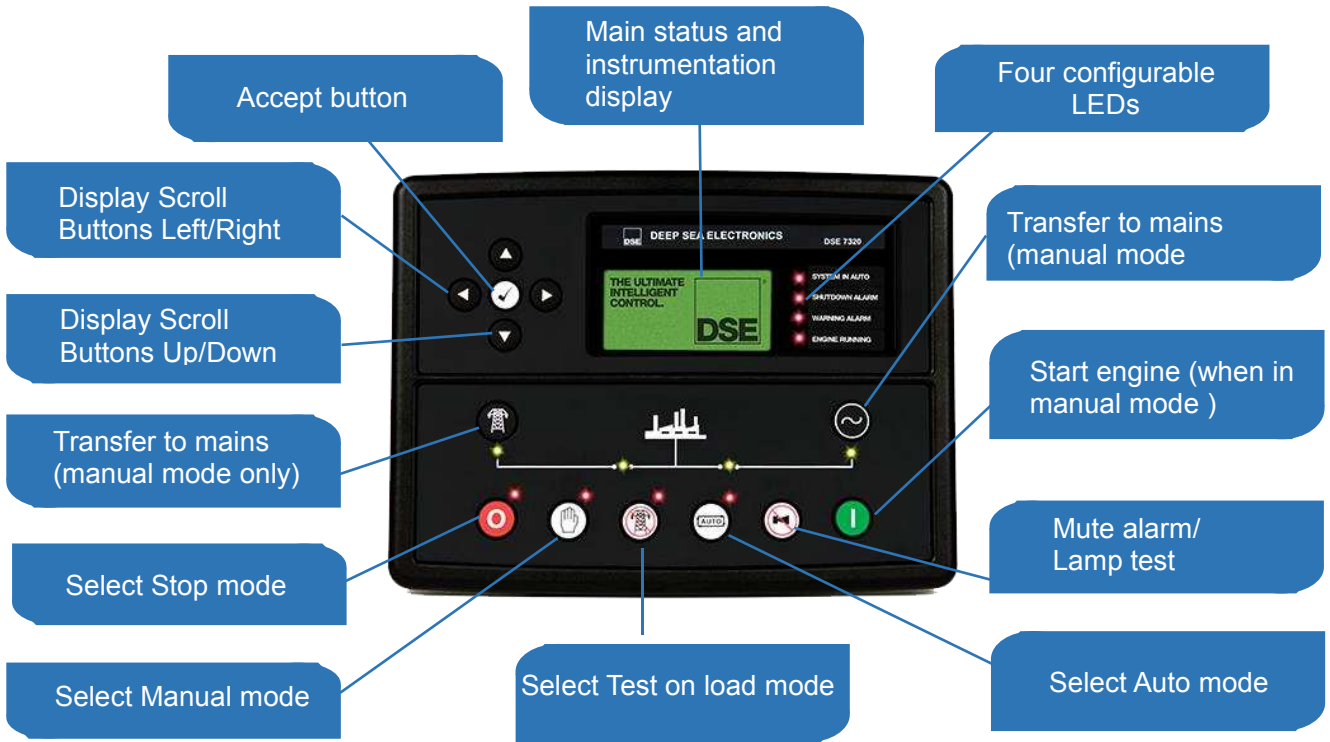

6.3.2 Description of DSE7320 control

- ◆ The DSE7320 is control panel for single gen-set applications. The panel has been developed from the DSE5320 and incorporates a number of advanced features to meet the most demanding on-site applications.
- ◆
- ◆ The DSE7320 is an Auto Mains (Utility) Failure Control panel. The panel has been designed to start and stop diesel and gas generating sets that include electronic and non-electronic engines. The DSE7320 includes the additional capability of being able to monitor a mains (utility) supply.
- ◆
- ◆ The DSE7320 is simple to operate and feature a user friendly menu layout for improved clarity. Enhanced features include a real time clock for improved event and performance monitoring, the ability to display any language on screen and a 132 x 64 pixel LCD display.

6.3.3 Start the engine



6.3.4 Stop the engine



Control Module Operation Guide

6.3.5 Viewing the instruments



The different pages of information is rolled displayed on LCD screen by repeatedly operating the next



page  button.

Once selected the page will remain on the LCD display until the user selects a different page or after an extended period of inactivity, the module will revert to the status display.

If no buttons are pressed upon entering an instrumentation page, the instruments will be displayed automatically subject to the setting of the Scroll Delay.

Alternatively, to scroll manually through all instruments on the currently selected page, press the

scroll  or  buttons. The 'auto scroll' is disabled.

To re-enable 'auto scroll' press the  or  buttons to scroll to the 'title' of the instrumentation page (ie Engine). When scrolling manually, the display will automatically return to the Status page if no buttons are pressed for the duration of the configurable LCD Page Timer.

If an alarm becomes active while viewing the status page, the display shows the Alarms page to draw the operator's attention to the alarm condition.

Page order

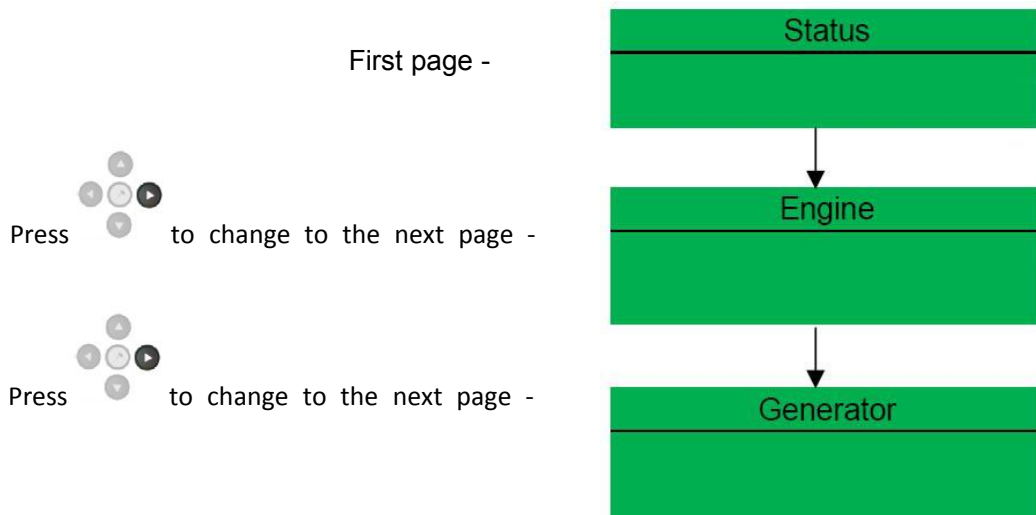

6.3.6 Instrument page content

Engine

- Engine Speed
- Oil Pressure
- Coolant Temperature
- Engine Battery Volts
- Run Time
- Fuel Level

.....

Generator

- Generator Voltage (ph-N)
- Generator Voltage (ph-ph)
- Generator Frequency
- Generator Current

- Generator Earth Current
- Generator Load (kW)
- Generator Load Capacity (kVA)
- Generator Power Factor
- Generator Load (kVAr)

.....

Mains

- Mains Voltage (ph-N)
- Mains Voltage (ph-ph)
- Mains Frequency

About

- Module Type
- Application Version



6.3.7 Automatic mode of operation

Activate auto mode by pressing the  pushbutton. An LED indicator beside the button confirms this action.

Auto mode will allow the generator to operate fully automatically, starting and stopping as required with no user intervention.



6.3.8 DSE7320 accessing the front panel configuration editor

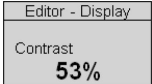

- ◆ Ensure the engine is at rest and the module is in STOP mode by pressing the Stop/Reset button.

- ◆ Press the Stop/Reset  and Info  buttons simultaneously, the icon  is displayed.

- ◆ Press the  button, the icon  is displayed.

Editing a parameter

- ◆ Press the  left or right  buttons to cycle to the section you wish to view/change.

- ◆ Press the  up or  down buttons to select the parameter you wish to view/change within the currently selected section.

- ◆ To edit the parameter, press  to enter edit mode. The parameter begins to flash to indicate that you are editing the value.

- ◆ Press the up or down buttons to change the parameter to the required value.

- ◆ Press  to save the value. The parameter ceases flashing to indicate that it has been saved.

- ◆ To exit the editor at any time, press and hold the  button.

Control Module Operation Guide

6.3.9 DSE7320 detailed in the configuration tables:

Section	Parameter as shown on display	Factory Settings
DISPLAY	Contrast	53%
	Language	English
	LCD Page Timer	5m
	Auto Scroll Delay	2s
EDITOR	Current Date and time	hh:mm
	Alt Config	Default Config
ENGINE	Oil Pressure Low Shutdown Threshold	1.03bar
	Oil Pressure Low Pre Alarm Threshold	1.17bar
	Coolant Temperature Low Warning Threshold	70°C
	Coolant Temperature High Pre Alarm Threshold	90°C
	Coolant Temperature High Shutdown Threshold	95°C
	Start Delay Timer	5s
	Pre Heat Timer	0s
	Crank Duration Timer	10s
	Crank Rest Timer	10s
	Safety On Delay	10s
	Smoke Limiting	0s
	Smoke Limiting Off	0s
	Warm Up Timer	0s
	Cool Down Timer	1m
	Engine Under Speed Shutdown Protection	Inactive
	Engine Under Speed Shutdown Threshold	1200RPM
	Engine Under Speed Warning	Inactive
	Engine Under Speed Warning Threshold	1350RPM
	Engine Over Speed Warning	Inactive
	Engine Over Speed Warning Threshold	1650RPM
	Engine Over Speed Shutdown Threshold	1710RPM
	Engine Speed Over shoot Delay	2s
	Engine Speed Overshoot	0s
	Fail To Stop Delay	30s
	Battery Under Voltage Warning	Active
	Battery Under voltage Warning Delay	1m
	Battery Under Voltage	10V
	Battery Over Voltage Warning	Active
	Battery Over Voltage Warning Delay	1m
	Battery Over Voltage Warning	30V
	Charge Alternator Failure Warning	Active
	Charge Alternator Failure Warning	6V
Charge Alternator Warning Delay	5s	
Charge Alternator Failure Shutdown	Active	
Charge Alternator Failure Shutdown	4.0V	
Charge Alternator Shutdown Delay	5s	
Droop control	Inactive	

Control Module Operation Guide

Section	Parameter as shown on display	Factory Settings
GENERATOR	Generator Under Voltage Shutdown	184V
	Generator Under Voltage Pre Alarm	196V
	Generator Voltage Nominal	230V
	Generator Over Voltage Pre Alarm	265V
	Generator Over Voltage Shutdown	277V
	Generator Under Frequency Shutdown	40Hz
	Generator Under Frequency Pre Alarm	42Hz
	Generator Frequency Nominal	50Hz
	Generator Over Frequency Pre Alarm	55Hz
	Generator Over Frequency Shutdown	57Hz
	Full Load Rating	500A
	Kw Overload Trip	100%
	Delayed Over Current	Active
	Delayed Over Current	100%
	AC System	3Phase,4Wire
	CT Primary	600A
	CT Secondary	5A
	Earth CT Primary	500A
	Earth Fault Trip	Inactive
	Earth Fault Trip	10%
Generator Transient Delay	0s	

Section	Parameter as shown on display	Factory Settings
MAINS	Mains Under Voltage Trip	184V
	Mains Over Voltage Trip	276V
	Mains Under Frequency Trip	45Hz
	Mains Over Frequency Trip	55Hz
	Mains Transient Delay	2s
	Return Delay	30s
	Mains Transfer Time	0.7s
	LCD Page Timer	5m
	Auto Scroll Delay	3s
	Start Delay Timer	5s
	Pre Heat Timer	0s
	Crank Duration Timer	10s
	Crank Rest Timer	10s
	Safety On Delay	10s
TIMERS	Smoke Limiting	0s
	Smoke Limiting Off	0s
	Warm Up Timer	0s
	Cool Down Timer	1m
	Speed Over shoot Delay	2s
	Fail To Stop Delay	30s
	Battery voltage Low Warning Delay	1m
Battery Voltage High Warning Delay	1m	
Return Delay	30s	
Generator Transient Delay	0s	
Mains Transient Delay	2s	
Mains Transfer Time	0.7s	

6.4 Other control system

According to the different needs of customers, Company provides control system such as: DSE702 (key starts), DSE8610 (parallel unit control system)...Please contact Company for further operation method of using these control.

7. Gensets Maintenance

7.1 Diesel engine maintenance

7.1.1 Cooling system

All Company's standard diesel generator sets are equipped with recycles water cooling system with fan. The whole system basically includes the following parts:

- Water pump
- Water pipe in engine body and gasket
- Thermostat
- Bypass pipe between thermostat and water pump
- Radiator
- Pipes and hose
- Oil cooler

In some nonstandard generator sets, such as separate radiator gensets, the radiator will be replaced by heat exchanger, expansion tank or remote water tank. If the remote water tank is installed in a high position, the transition bank needs to be added to avoid the damage of heat exchanger caused by the high internal pressure, meanwhile, all series of Company's generator sets can add coolant filter which can:

- 1) Stop the impurity into the coolant and avoid the scale forming in the cooling system;
- 2) Improve the antirust protection capacity of the coolant

The dunghill on the surface of the radiator can reduce the cooling capacity largely. So it is necessary to wash the radiator and keep it clean always.

(1). Coolant

Coolant has three functions:

- 1) Supply enough heat exchange capacity
- 2) Stop the rusting of the whole cooling system
- 3) Offer enough anti-frost protection

Coolant can be either mixture of water and antirust or mixture of water and antifreeze. The PH data of water should be 6-8, so we suggest choosing pure water. Pls do not use water only for coolant.

In cold climate, the coolant should contain 40%-60% of antifreeze. When the proportion of antifreeze is 40%, the freezing point can reduce to -25Centigrade. When the proportion is 60%, the freezing point can reach to -56Centigrade. We suggest customer to choose 50% antifreeze (glycol) and 50% pure water as coolant and well mix them outside before fill into the radiator.

Antifreeze content:				
Temperature:	-5°C	-25°C	-40°C	-56°C
Proportion:	40%	40%	50%	60%

Gensets Maintenance

More than 60% antifreeze is not recommended because it will reduce the anti-freezing protect capacity. Glycol is the first choice of antifreeze.

In warm climate above frozen point, the coolant should be mixture of antirust fluid instead of antifreeze. The best proportion of antirust and water is around 1:30, which will have antirust function and without influence of cooling of generator. After fill the coolant, start the machine to heat the engine and make the antirust distribute uniformity inside the engine. The diethylene glycol is recommended antirust.

IMPORTANT! Do not mix any kind of antifreeze and antirust fluid together which will form lots of bubble and reduce the cooling capacity.

IMPORTANT! Forbid to use Alcohol in cooling system.

DANGEROUS! Antifreeze and antirust fluid is dangerous for human. Do not drink it. Don't leave chance to them to touch skin and eyes. Operate according to the package instruction.



(2). Coolant effluent

Before long term storage of generator sets, pls drain away the coolant. Make sure the machine is closed and cool down before this operation. Generally required to drain away all of the coolant in radiator, engine body, water pump (if have outlet), oil cooler (if have outlet), coolant heater (if have outlet), water filter. The different engine model has different water outlet position.

(3). Coolant replacing

Coolant need to be replaced per half a year at least to avoid the deposition in cooling system. The other important reason to replace the coolant is avoid the increasing rust which may affect the additive validity and damage the water temperature sensor.

IMPORTANT! When replacing the coolant, rinse the whole system by clean water. Only when the water flushed out is clean enough, and then starts to fill new coolant.

WARNING! Make sure the engine is stopped and completely cool down before this operation. Unless emergency, do not open the water fill-in gap when the engine temperature is still high. Otherwise the steam or high temperature coolant may spout out.

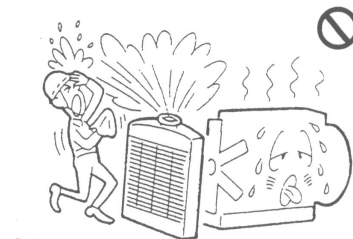

Pls pay attention to the following items when add the coolant:

- 1) Don't fill too fast, avoid the bubble isolation.
- 2) The liquid level should be located 5cm under the fill port plug welding point. After filling, pls start and pre-heat the machine. Meanwhile inspect the liquid level.

IMPORTANT: Keep the same content coolant as former.

(4). Clean the radiator exterior

Dismantle the protection cover of the radiator. Wash the radiator with clean water and neutral detergent. Choose the soft brush as tool. Be careful, do not damage the heat sink.

IMPORTANT: Do not use the high-pressure water pipe to clean the radiator.

7.1.2 Lubricating system

(1). Lubrication oil

The main function of lubrication oil is supply the long lasting protection oil film between moving parts of diesel engine to reduce the attrition and abrasion. Meanwhile, it can prevent the corrosion in the parts surfaces. Cylinders in high temperature and bearing are heavily reliant on the lubrication oil film. Lubrication oil is also a very important coolant for lots of engine parts.

Pls choose suitable lubrication oil described in the following table:

Lub.Oil grade	standard	Viscosity index
D5, D4	CCMC	SEA
CE, CF	API	SEA
CF-4, CG-4	API	SEA

Remark:

CCMC - Euro Luboil Quality standard

APT- American Petroleum Institute Quality standard

SEA - standard from Society of Automotive

Engineers for temperature / viscosity. Like 15w/40 etc...

IMPORTANT! Do not start or operate the engine when open the cap of oil, avoid the spraying.

IMPORTANT! Using the lubricant which doesn't meet the Specifications may lead to the mis-operation and reliability deterioration.

IMPORTANT! Using the wrong type or low grade lubricant will cause the warranty unavailable.

WARNING! Mix different specifications or different brands of lubricants is forbidden.

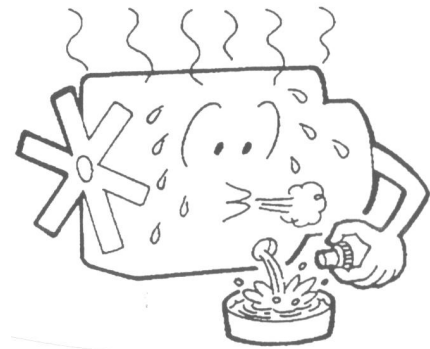

(2). Lubrication oil and oil filter replacing

Renewal of oil must comply with the recommended change interval. While replacing the oil, do replace the oil filter.

- 1) Pump extracts lubricant;
- 2) Clean filter mount, avoiding the dirt into the engine when install the new filter.

IMPORTANT! Hot lubricant will hurt the skin, Pls avoid to touch it.

- 3) Turn off the bottom plug, drain off the lubricant; Screw the bottom plug, replace the filter.
- 4) Fill lubricant into the new filter. Coat some lubricant in the gasket, screw the filter to the engine by hand until gasket touches the base, and then tighten more half circle.

6) Add the lubrication to suitable level

7) Start the generator, check if the oil pressure is normal, and any leak around the filter.

IMPORTANT! Add the lubrication and make sure the level is between the Max and Min mark.

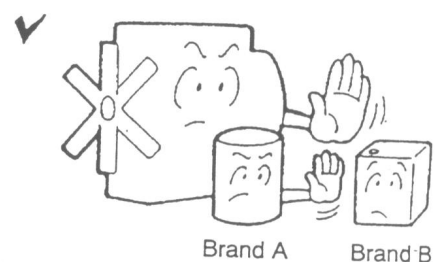

Gensets Maintenance

7.1.3 Fuel system

Please choose the qualified fuel according to the following instruction. Please make sure of the cleanness when refueling and fuel system operation. Any work involving injection pump or injector need to be carried out by a professional technician. Otherwise, the engine warranty will expire!

WARNING! When operating in the fuel system, you must make sure that the engine has cooled down. Fuel spilled on hot surfaces or electrical components may cause a fire.

The fuel system of standard configuration generator, including the main components: the base tank, fuel pump, fuel oil filter, manual oil pump , fuel injectors and related pipeline.

(1). Fuel specification.

Choosing the recommended fuel is vital important for environment and reliability of operation.

Fuel should conform to Chinese and International commercial oil standards, Such as:

- EN590 (according to China nation environment and cooling requirements)
- ASTM-D975-No 1-D, 2-D
- JIS KK2204

Sulfur content: According to the laws of the different countries, if the sulfur content exceeds 0.5% of the total weight, it should be appropriate to shorten the oil change interval.

Customer must use the fuel recommended in the operating manual. For diesel engines, the use of low quality fuel may render the control rod cement and over-speed rotation of the engine, resulting generator sets damage or serious personal injury. Poor quality fuel will shorten the maintenance cycle, increasing maintenance costs; reduce the service life of the unit normal.

For Chinese users who are not in frost areas, it is recommended using 0# light diesel. In other areas, pls chose better quality diesel with low temperature resistance.

IMPORTANT! There is a risk of fire and explosion when refueling, no smoking.

IMPORTANT! Do not let the fuel overflow, seal the fuel cap safety.

The water in the fuel can cause corrosion to metal parts of the fuel system, and make bacteria and micro-organisms grow in the tank easily, leading to the filter blocking.

Furthermore, in the cold weather water will freeze and influence

normal working of the fuel system. The particulate impurities may block the key part like fuel pump, then impact the normal fuel supply /or damage generator.

When the generator sets keep long time working or the fuel moisture content is relatively large, it is recommended to install oil-water separator by the final user.

All model generators of Company can add oil-water separator according to customer's requirements. Oil-water separator is not the standard configuration. User could list this special requirement when ordering generator.

IMPORTANT! Must be sure that no water or any other impurities in the fuel into the engine.

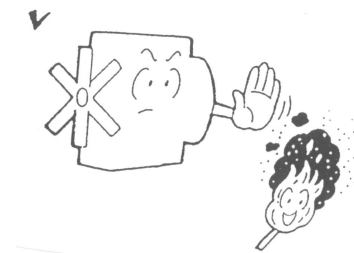

(2). Replace the fuel filter

Keep it clean! Do not let any dirt into the fuel system.

WARNING! To avoid fuel spilled on the hot surface and cause a fire, replacing the fuel filter must be carried out in the cooler conditions.

1) Remove the filter. Coat a little oil on the new filter gasket. Hand screw on the filter so that the gasket and seat contact. Then tighten more semi-circle, do not screwed more. Exhaust air from the fuel system.

2) Start the machine, check for leaks.

(3). The fuel injection pump

The fuel injection pumps used in Company diesel generator sets are of superior quality and reliable performance, which can ensure long term operation.

(4). Nozzle

The function of the nozzle is:

To equally distribute fuel for reliable ignition and combustion

--To directly inject the fuel into the combustion chamber, and to provide the best mix of fuel and air. The injection pressure can be adjusted by the spring in advance.

(5). Exhaust system

If there is air in the fuel system, it may affect the generator sets normal start and running. The air exhaust of the fuel system can be processed according to the following method:

Check and make sure that there is no loose with fuel line connector. Loosen the exhaust screw on the fuel filter, press the manual pump until no bubbles in the overflowed fuel, then tighten the screw. Pump the fuel 15-20 times continually, check the leaks.

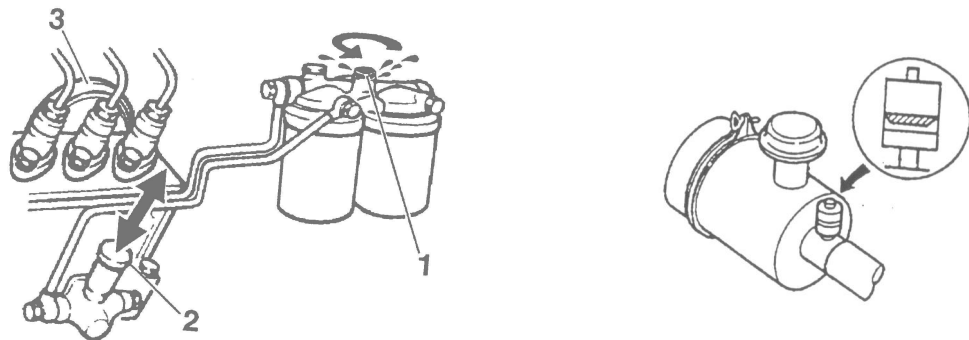

1-exhaust screw

2- manual fuel pump

7.1.4 Intake and exhaust system

(1). The air intake system

The air intake system is an extremely important part of the engine installation. It has a direct and important impact for power output, fuel consumption, air exhaust and service life of the engine. The design and installation of the air intake system must guarantee that the engine can have clean and dry cold air with minimal resistance, and have reliable ventilation and durability.

The intake system is mainly composed of the following parts:

--Intake pipe

Gensets Maintenance

--Air filter

Wherein the installation position of the intake pipe has the following requirements:

---Dust concentrations is as little as possible

---The temperature is as closer as possible to the ambient

---Water or other substances can not enter

Must avoid the intake of exhaust air and hot air into the intake system

The design and installation of the intake system should guarantee the fuel burning, engine body cooling and generator room ventilation.

Company series diesel generator sets are fitted with dry paper type air filter which comes with a resistance indicator that can indicate the blockage of the filter. Every time before starting the machine, please check the resistance indicator. When you see the red flag is completely exposed from the window, please replace the air filter immediately. The old filter should be replaced for scrap processing and can not be re-use any more.

WARNING! When replacing the air filter, be careful to avoid the dirt drop into the air intake system.

(2). Exhaust system

The design and installation of the exhaust system should consider the following aspects:

--To ensure that the back pressure of the entire exhaust system is not higher than the allowable value.

--Support the exhaust system and avoid the exhaust manifold and turbocharger pressed by longitudinal and lateral force.

--Reserved extra space for thermal expansion and contraction (especially when the exhaust pipe is over 10 meters in length, the extra space should be determined by computing the telescoping amount and take the appropriate installation measures)

--Enough space for vibration

--Reduce exhaust noise

IMPORTANT! The back pressure of the exhaust system must be kept within a predetermined limit.

Standard back pressure data and the calculation method of the exhaust backpressure can be consulted from Company agency or contact Company directly.

High back pressure may cause:

--Output power loss

--Fuel economy deterioration

--Exhaust temperature rising

Company series generator sets choose heavy-duty industry silencer which works to absorb noise through sound absorption bush fitted inside the muffler, and the reduction of noise range is wide.

Plus the back pressure value of muffler and exhaust pipe to get the back pressure value of the whole system.

If install more than one unit generator sets, do not share one exhaust flue for these units.

Use the bellows pipe to separate the exhaust pipe and turbocharger which has three functions:

--Isolate the vibration and weight of the exhaust duct from the engine.

--Compensate the thermal expansion of the exhaust duct.

--Compensate the side-sway of the pendulum movement when generator sets startup and shutdown, if the generator sets are mounted on anti-vibration base.

WARNING! Rain or condensation water into the diesel engine will cause serious damage. Therefore, install a waterspout in the long exhaust pipes and the position should be as close as possible to the diesel engine.

7.2 Alternator maintenance

7.2.1 Inspection before start

(1). Earthing

The alternator is unearthed from the factory, and it must be properly earthed according to the site regulations.

DANGER! Incorrect earthing and protection will result in loss of life and personal injury.

2. Reconnection

Most alternators can be re-wired to have different output voltages. For the reconnection method, please refer to “Alternator installation and maintenance manual”. Before changing the voltage, check whether other components are suitable for new voltage, such as power-off switch, current transformers, cables and ammeter, voltmeter, etc.

3. Insulation check

When start the generator sets which is not working for a long time, first of all, check the resistance of the generator coil. In this case, the automatic voltage regulator (AVR) and all control lines should be disconnected. Disconnect the wiring between midpoint and ground, measure the resistance between the terminal and the ground with a 500v megger of similar instrument. The insulation resistance of machine-to-ground should be more than 2MΩ. If the data is less than 2 MΩ, the drying treatment must be done to the coil.

Detailed test steps can refer to “Alternator installation and maintenance manual”.

7.2.2 Maintenance considerations:

It is recommended that the user do regular inspection and cleaning to the generator and all attachments.

Test the coil insulation before the first use as per the steps which are mentioned in “Alternator installation and maintenance manual”. If the alternator will be stored for long period, please inspect the winding coil insulation every 3-6 months according to the local humidity. It is recommended that in the high humidity areas, the user can install the space heater to keep the alternator dry. This will be helpful to reduce the failure rate and ensure the normal service life.

The alternator inside and outside should be cleaned on a regular basis, and the clean frequency depends on the local environment. When clean the alternator, follow these steps: cut off all the power, wipe all of the dust, dirt, grease, water and any liquid, also the ventilation net. Because once these things drop into the coil, the overheating or insulation destruction will happen. It is better to clean the dust and dirt by vacuum sweeper. Do not use the inflatable or high pressure water jet.

The “Alternator installation and maintenance manual” provides more detailed maintenance information and guidance to find fault.

WARNING! Incorrect installation, operation, maintenance or replacement of parts will result in death or serious injury or damage to the equipment. The service personnel must have qualifications of the electrical and mechanical service.

DANGER! Electric shock can cause serious injury or even death.

IMPORTANT! During the electrical wiring, it is strictly forbidden to connect the ground line and generator midline directly.

Gensets Maintenance

7.3 Battery instruction and maintenance

WARNING! There is a danger of fire and explosion.

Open flame or sparks are forbidden near the battery.

WARNING! Never mistake the positive and negative terminals

of the battery, otherwise it will lead to sparks and explosions

WARNING! The battery electrolyte contains extremely corrosive

sulfuric acid. During the maintenance of battery, the operator

should wear acid resistant aprons and wear a mask or protective

goggles. When add the electrolyte, please slow down and prevent

against splashing. Once the electrolyte is accidentally splashed on the skin or clothing,

wash immediately with plenty of water.



7.3.1 Connect and disconnect

First, connect the red wire (+) to the battery positive pole (+), then connect the black wire (-) to the battery negative pole (-).

When disconnect the battery, disconnect the negative pole (-) (black wire) firstly, and then disconnect the positive pole (+) (red wire).

7.3.2 Cleanup

Keep the battery dry and clean. Oxides and dirt on the battery and terminals will cause a short circuit, the voltage drop and the discharge, particularly in wet weather. Clean the battery terminals and cables with a brass brush to remove the oxides. Tighten the cable connector and coat with a protective grease or Vaseline at the joints.

7.3.3 The battery charging

Company series generator sets are equipped with maintenance-free battery and battery float charger on the control panel. If the generator sets are not used for a long time or first starting, the user should measure the battery voltage. If the voltage is too low, the user should charge the battery with the battery float charger.

The power supply of battery float charger is standard single phase mains voltage (AC220v). Its main function is to avoid the excessive discharge when the generator sets is not used for a long time which will cause the battery damage or start failure. The user only needs to connect the AC220V single phase mains with the controller connection terminal, no need to add any other battery charger. The advantage is that the user only need to connect the power supply correctly and there is no need to do any additional maintenance of battery. Moreover, due to its unique way of charging and comprehensive protection of over-current and over-voltage, it will not cause any damage to the battery when charging with the standard AC220V voltage. When generator sets start successfully, the electric control system will disconnect the float circuit automatically. This plays a better protective effect on the charger and the battery at the same time.

7.4 Heater

There are three types of heaters for generator sets:

---**Water jacket heater:** It is used to heat the coolant automatically when the heater is connected with single phase state power correctly. When the generator sets is in standby mode, the device can automatically detect the coolant temperature and start to heat once the temperature is below the set limit. Until the temperature is raised to about 50 centigrade, it will automatically stop heating. The water jacket heater must be installed for possible icy area. The power of the heater is 220V AC mains.

NOTE: Be sure to stop the water jacket heater during the generator sets operation. Otherwise it may burn out. Company has already designed the control functions for our installed heaters which can make sure the power automatically cut off when the generator sets start to work.

NOTE: The manual maintenance valve on the heater pipeline should be open.

---**Anti-condensation heater:** When the generator sets are used in the high ambient humidity, the anti-condensation heater needs to be installed in the alternator to avoid the insulation performance reduction caused by the internal condensation. Generally the power supply is generator battery.

---**Oil heater.** It is used to heat the lubrication oil when the Oil Heater is connected with 220V Single phase state power. When the generator sets is in standby mode, the device can automatically detects the oil temperature and start to heat once the temperature is below the set limit. Until the temperature is raised to about 40 centigrade, it will automatically stop heating. The lubrication heater must be installed for extremely cold area. The power of the heater is 220V state power.

8. Maintenance Plan

Correct maintenance is the necessary protection for long-term trouble-free operation and normal power supply. Therefore, all users should maintain the diesel generator sets according to the following steps and content.

Note: The maintenance content for different types of generator sets may be slightly different. This section is for reference only. For more details, please refer to the “Engine operation manual” and “Alternator installation and maintenance manual”.

8.1 Routine maintenance

8.1.1 Before each start

- 1). Clean the surface
- 2). Check the coolant level

The coolant level should be as close as possible to 3cm below flap welding surface, and it is not recommended to add too much.

- 3). Check appearance of radiator core and intercooler.

If the radiator and intercooler is too dirty, please remove the protection device and wash it with a low concentration of detergent. Please be careful not to spoil the sheet above.

WARNING! Do not use high-pressure water to rinse and Install it correctly once finish washing.

- 4). Check the air filter blockage.

If the clogging indicator is in the red zone, please replace the filter immediately when the generator stops. After replacing, press the red button to reset the indicator. The replaced filter does not allow reuse.

IMPORTANT! If the generator sets have been kept on working, the filter should be checked every 8 working hours. Before the indicator shows in the red area, do not move it.

- 5). Check the lubrication oil level.

IMPORTANT! Make sure the oil level is between the maximum and minimum of the dipstick scale value.

Check the oil level every 8 working hours if the generator set continuous working.

IMPORTANT! The used filter can not be reused!

- 6). Check whether the control system electrical connection is loose or not.

8.1.2 After running

- 1). Carefully check and tighten the rotating parts bolts, especially the connecting bolts of fuel pump, water pump, pulley and fan, and tighten the anchor bolts.
- 2). Check fluid (coolant, fuel, oil) leakage, clean-up if necessary.
- 3). Exclude the simple breakdown and irregularities in operation.
- 4). Clean up the dust on the air filter element.
- 5). Check the lubrication level; if necessary, add equal quality oil which can meet the technical requirements.
- 6). Check the coolant level; if necessary, add some pure water.
- 7). Check whether the electrical connection of the control system is loose or not.
- 8). Comprehensively clean the surface of the whole generator sets.

8.2 Every 200-400 working hours

Besides the above maintenance projects, add the following:

- 1). Check if the battery is abnormal.
- 2). Check the filters (water, oil, fuel); replace it if necessary.

- 3). Check and adjust fan belt tightness.
- 4). If necessary, add or replace the coolant in radiator and engine body.
- 5). Check if the wiring thread of the alternator and electric control parts is solid.
- 6). Replace the oil.

IMPORTANT! After the first 50 working hours running of a new generator set, do replace all of the oil and filters (The oil grade is not lower than the API-CE standard)

- 7). Replace the oil filter and bypass filter.

Use special tools to remove the filter. Ensure that full fill the oil to the new filter to drain the air, and then screw it on by hand, once come into contact with the gasket, tighten 3/4 turn more. Start the generator sets and check whether there is leakage.

- 8). Replace the air filter and fuel filter

Use special tools to remove the fuel filter. Lubricate the liner and screw the new filter full-filled of clean diesel. Once come into contact with the gasket, screw 1-2 turns more.

Be careful! Can not have any dust entering the fuel system.

WARNING! The fuel filters can be replaced after the generator set has cooled completely, in order to avoid fire caused by diesel spilled into the drain pipe.

- 9). Check and adjust the valve clearance (different engines have different schedule of valve clearance adjustment, Please refer to "Engine operation manual")

8.3 Every 800 working hours

- 1). If possible, thoroughly remove the accumulated sludge in the diesel tap.
- 2). Check if there is any leakage in the inlet/outlet pipe of the turbocharger.
- 3). Check if there is any damage of the pipe connection fasteners, if necessary, replace and fasten the new ones.
- 4). Check the fuel injection pressure and atomization, if necessary, clean the injector coupled parts, re-adjust the fuel injection pressure; replace the default fuel injector nozzle.
- 5). Check and adjust the fuel injection pump advance angle, replace the injection pump oil.
- 6). Clean the fuel tank and pipes.
- 7). Clean the oil pan, oil filter.
- 8). Inspect and tight rod bolts, main bearing bolts, cylinder head bolts.
- 9). Check the battery electrolyte, if necessary, add some.
- 10). Check proofread instrument.
- 11). Check and adjust the excitation circuit.

8.4 Every 1200 working hours

- 1). Complete all of the checking works of every 800 working hours.
- 2). Check and adjust valve clearance (different engines have different schedule of valve clearance adjustment, Please refer to "Engine operation manual").

IMPORTANT! Stop the generator set when checking.

8.5 Per 2500hours or as needed

- 1). Complete all works of every 1200hours.
- 2). Check the injection nozzle.

The tightening torque of injection nozzle is 50N.m, for turning it is 15-20N.m. If necessary, replace the nozzle.

9. Troubleshooting Guide

IMPORTANT! Just the professionally trained qualified engineers and technicians can check the injection system.

3). Check the turbocharger work situation and do a comprehensive inspection of diesel engine and its accessories by professional engineer.

9.1 Diesel engine

9.1.1. Engine start failure

Reason:	Approach:
A) Lack of battery charging	A) Charging up accumulator, replace accumulator if necessary.
B) Control circuit poor contact/circuit break	B) Exclude any disconnection/poor contact failure, check connector oxidation and change it if necessary. Clean oxide on the surface.
C) Control module failure	C) Replace the control module
D) Start relays failure	D) Replace the starter relay
E) Start motor failure	E) Contact with authorized personnel
F) Any malfunction of the start circuit	F) Check all the other parts of the start circuit.

9.1.2. Engine start difficult or can not start, exhaust pipe smoke

Reason:	Approach:
A) Start motor speed is too low	A) Refer to "can not start the engine" section.
B) Fuel relay failure	B) Repair /replace the fuel relay.
C) Wrong use of the cold start device	C) View the user book to check how to operate the cold start system.
D) Fuel filter blockage	D) Replace the fuel filter
E) Air exist in the fuel system	E) Vent the air from fuel filter
F) Suction fuel duct blockage	F) Clean the duct
G) Air intake system blockage	G) Clean the intake system
H) Water in fuel	H) Replace the fuel and install the oil-water separator.
I) Use the wrong type or brand of the fuel	I) Replace the fuel and try to start the engine
J) Injection pump inlet and return pipe connector is loose	J) Tighten the pipe connector.
K) Fuel pump failure	K) Check /repair fuel pump, if necessary, replace it.
L) Fuel supply timing wrong	L) Check fuel injection pump data and adjust.
M) Valve timing wrong	M) Adjust to the required data
N) Exhaust duct obstruction	N) Inspect the exhaust pipe is blocked or not.

9.1.3. Engine start difficult or can not start, exhaust pipe no smoke.

Reason:	Approach:
A) No oil in the fuel tank	A) Add fuel
B) Stop solenoid failure	B) Check electromagnet, replace it if necessary.
C) Fuel delay failure	C) Repair /Replace the fuel relay.
D) No oil spray from injector	D) Loose the injection pump hose, start the engine at the same time, check whether the fuel overflow
E) Oil pump suction pipe joints loose	E) Tighten all of the filters pipe joints between the fuel tank and fuel pump.
F) Fuel filter blocking or suction tube obstruction	F) Replace fuel filter, Check the fuel hose non-blocking
G) Intake or exhaust system obstruction	G) Check the intake and exhaust system has non-blocking
H) Fuel pump failure	H) Check/repair fuel pump, replace it if necessary.
I) Injector hole obstruction	I) Check/ clean or replace the fuel injector

9.1.4. Engine can start but can not keep running

Reason:	Approach:
A) Air exist in the fuel system	A) Vent the air out from the fuel system
B) Fuel relay failure	B) Repair/replace the fuel relay
C) Fuel system leak or blockage	C) Check the fuel line
D) Fuel filter blockage	D) Replace fuel filter
E) Using the wrong type or grade of fuel	E) Replace the fuel
F) Water in fuel	F) Replace the fuel and install the oil-water separator
G) Intake system blocking	G) Clean intake line

9.1.5. Black smoke

Reason:	Approach:
A) intake /exhaust system blocking	A) Check intake /exhaust system have a non-blocking
B) injector fault	B) Check/adjust or replace injector
C) cold start system failure	C) Check the start system
D) using wrong type or brand of fuel	D) Replace the fuel
E) exhaust duct obstruction	E) Check the exhaust pipe is blocked or not, check the pipe size is correct or not.
F) wrong valve clearance	F) Adjust the valve clearance
G) return pipe blocking	G) Check the return line non-blocking

Troubleshooting Guide

9.1.6. Take the blue smoke or white smoke

Reason:	Approach:
A) Using the wrong type of lubricant	A) Replace the lubrication oil and filters and make sure to choose the correct type of oil.
B) Cold start system malfunction	B) Install the cold start device, inspect, repair or replace it if necessary.
C) Excessive engine lubrication oil	C) Check the oil level
D) Turbocharger seals and bearing wear	D) Repair /replace turbocharger
E) Using the wrong type or grade of fuel	E) Replace fuel
F) Go over the engine overhaul deadline	F) Engine overhaul
G) Water leak of the cylinder head	G) Inspect cylinder head and gasket, replace it if necessary.

9.1.7. Engine can not reach to rated speed

Reason:	Approach:
A) Overloaded too much	● Reduce the load
B) Tachometer mistake	● Check the speed by handheld or digital tachometer
C) Suction tube obstruction	● Check the inlet non-blocking, replace it if necessary.
D) Government failure or improper settings	● Check/adjust the governor
E) Government mix speed is set too low	● Check/adjust the governor
F) Water in fuel	● Replace the fuel, install oil-water separator

9.1.8. Engine can not be shut down

Reason:	Approach:
H) Poor contact / open circuit	1. Exclude any disconnection /poor contact failure, inspect the connector for oxidation, and clean it if necessary.
I) Controller stop button failure	2. Replace/repair controller stop button
J) Stop solenoid failure	3. Check /replace the stop solenoid
K) Fuel return pipe blocking	4. Check the return pipe non-blocking, distorting or depression.

9.1.9. Engine output power shortage

<p>Reason:</p> <ul style="list-style-type: none"> ■ Overload too much ■ Decline of power caused by high altitude ■ High ambient temperature ■ Fuel duct obstruction ■ Intake or exhaust system blocking ■ Air exist in fuel – air bubbles in fuel system ■ Return pipe blocked or the fuel tank with poor ventilation ■ Using the wrong type or grade of fuel ■ Injection pump failure 	<p>Approach:</p> <ul style="list-style-type: none"> A) Reduce the load B) Correct the power output when the altitude is more than 1000meters. C) Correct the power output when the temperature is over 40Centigrade D) Inspect the fuel system non-blocking E) Inspect the air intake and exhaust system have a non-blocking F) Vent the air from fuel, tighten the pipe connector and filter. G) Check the fuel return system had non-blocking H) Replace the fuel I) Check /replace the fuel injection pump
---	--

9.1.10. Low oil pressure

<p>Reason:</p> <ol style="list-style-type: none"> 1. lubricants bit inappropriate 2. oil pressure meter /sensor failure 3. wrong oil grade 4. oil filter blocking 	<p>Approach:</p> <ul style="list-style-type: none"> J) Check for lubricant leaks. Add or emission lubricants. K) Check the oil pressure meter /sensor L) Replace oil, choose the correct grade M) Replace the oil filter
---	--

9.1.11. High water temperature

<p>Reason:</p> <ul style="list-style-type: none"> O) Coolant level is too low P) The radiator is blocked or damaged Q) Radiator hose depression or obstruction R) Fan drive belt slack S) Lubricants bit inappropriate T) Thermometer failure U) Water temperature sensor failure V) Fan damaged W) Water pipe obstruction X) Water pump failure Y) Thermostat failure 	<p>Approach:</p> <ul style="list-style-type: none"> A) Add coolant B) Clean the radiator according to the instruction, repair it if necessary. C) Check the hose, replace if necessary. D) Check the tension of the belt, tight if necessary. E) Add or emission lubricants. Check the oil dipstick scale. F) Inspect/repair the water temperature meter. Replace if necessary. G) Check /repair the water temperature sensor H) Replace the fan I) Check and clean the water pipes J) Check/repair the water pump K) Check/repair the thermostat
---	--

Troubleshooting Guide

9.1.12. Engine running is unstable

<p>Reason:</p> <ul style="list-style-type: none"> ■ Fuel pipe obstruction ■ Fuel pump failure ■ Fuel filter is dirty ■ Governor is set incorrectly ■ Injector failure ■ Fuel tank ventilation blocked ■ Air exist in fuel system ■ Air filter blocked ■ Valve clearance is incorrect ■ Lubricants excessive, or use the wrong grade/brand of oil. 	<p>Approach:</p> <ul style="list-style-type: none"> a) Check /replace the fuel pipe b) Check/repair fuel pump, replace if necessary c) Replace the fuel filter d) Adjust /replace governor e) Check /adjust or replace injector f) Clean-up / install the ventilation tube g) Vent the air from fuel h) Clean /replace air filter i) Inspect /adjust valve clearance j) Check /adjust the amount of oil or replace it.
---	--

9.1.13. Engine vibration

<p>Reason:</p> <ul style="list-style-type: none"> ■ Injector fault ■ The governor is set incorrectly ■ Engine assembly fault ■ Injection pump failure ■ Flywheel housing, flywheel concentricity doesn't meet the requirements 	<p>Approach:</p> <ul style="list-style-type: none"> A) Check /repair injector B) Adjust / replace governor C) Contact with authorized personnel D) Contact with agency to repair the pump E) Contact with agency
---	---

9.2 Alternator

9.2.1. No voltage output when running

- A. Check the connection of AVR F1-F2 is correct and reliable.
- B. Check the outlet is correct
- C. Check the remanence voltage, magnetized if necessary
- D. Check the fuse in control box is normal

9.2.2. Output voltage is instable

- A. Check the speed of the unit is stable.
- B. Check the settings of AVR is correct

9.2.3. Output voltage is too high

- A. Check whether the engine speed is too high or not.
- B. Check/ adjust the settings of AVR

9.2.4. No-load voltage is too low

- A. Check the engine speed is too low
- B. Check the settings of AVR

9.2.5. Load voltage is too low

- A. Check the engine speed
- B. Check whether it is overloaded or not.
- C. Check/ adjust the settings of AVR

9.3 Electric control

9.3.1. Generator sets don't start when press down the start button.

- A. Check whether any loose happened in the circuit or not, whether the controller is good or not.
- B. Check any malfunction indication, repair the faults and reset the corresponding fault information.
- C. Check that the emergency stop button is relaxed.
- D. Check the battery voltage. If the voltage is too low, recharge the battery to full. If the voltage is normal, please

check whether the voltage signal is sent to every control units step by step according to the circuit diagram, such as the throttle solenoid valve and starting motor etc...

9.3.2. Generator sets can not start even the start motor is workable

- A. Check the fuel level and ensure that the tubing is properly connected
- B. Check the fuel relay abnormal
- C. Check the fuel delivery system if there is air and clogged
- D. Check the air filter is blocked or not
- E. In cold regions, ensure the machine is preheated before starting.

9.3.3. High water temperature fault alarm/shutdown

- A. Check whether it is overloaded
- B. Check the radiator is blocked
- C. Check the fan belt tightness
- D. Check the coolant level after the machine is completely cooled down.
- E. Check whether the water temperature sensor is damaged or not
- F. Check whether the thermostat valve is correctly opened
- G. Check whether the gap between the pump and radiator is correct.
- H. Confirm the temperature of the generator room is not higher than 40centigrade

9.3.4. Low oil pressure alarm / shutdown

- A. Check the oil level
- B. Check the oil pressure sensor is damaged
- C. Check the oil filter and duct is not blocked
- D. Check the oil quality and viscosity
- E. Check the oil temperature

9.3.5. Over speed shutdown

- A. Check the setting of the overspeed protection in the controller, adjust if impropriety
- B. For mechanical type governor, inspect the throttle lever is flexible and ensure proper regulation.
- C. For electrical type governor, check the settings of the governor and adjust if necessary.
- D. reset the alarm signal on the screen after troubleshooting.

9.3.6. High voltage alarm

- A. Check the high voltage protection limit setting in the controller, adjust if impropriety
- B. Measure the actual value of the output voltage
- C. Confirm that the display instrument is no deviation
- D. If the actual voltage is too high, check and adjust the AVR following the steps
- E. Confirm the speed /frequency is normal
- F. If the actual voltage is normal, check the voltage display circuit

Troubleshooting Guide

9.3.7. Low voltage alarm

- A. Check the low voltage protection limit setting in the controller, adjust if impropriety.
- B. Measure the actual value of the output voltage
- C. Confirm that the display instrument is no deviation
- D. If the actual voltage is too low, check and adjust the AVR following the steps.
- E. Confirm the speed /frequency is normal
- F. If the actual voltage is normal, check the voltage display circuit.
- G. Confirm the load changes slightly when an alarm occurs
- H. Ensure that the generator sets is not overload working

9.3.8. In automatic mode, the generator sets can not start up automatically

- A. Check the connection between generator sets and ATS is correct
- B. Confirm the ATS converter switch is not in "AUTO" position
- C. Confirm the ATS control wire is not loose
- D. Check whether the fuel relay is normal, replace if necessary

9.3.9. In automatic mode, the generator sets can not shutdown automatically

- A. Confirm the utility is completely back to normal
- B. Confirm it is still in the set time of automatically shutdown delay
- C. Check the fuel relay is normal, replace if necessary
- D. Check the stop solenoid is normal, replace if necessary

10. Warranty Guide

Please check the “Company WARRANTY GUIDE”



SG ENERGY

SGEnergy Power Products
10 Garden Blvd
Dingley Victoria 3172
Australia

www.sgenenergy.com.au